

User Manual

EM10 Series Frequency Inverter



Preface

Thank you for purchasing the EM10 series frequency inverter.

EM10 series inverter is our company adopted the new concept to research and developed high-performance product. With unique control model, this inverter can realize high torque, high precision, wide variable speed and low noise drive; And PID regulation, simple PLC, flexible input and output terminals, Auto voltage regulation, rapid Current Limit, Torque limited and control, field bus control and a series of practical operation, control function, which provide a highly integrated solution for equipment manufacturers and customers, in speed, energy saving, automatic control and other aspects, to meet the application demands for different customers.

Before unpacking, please check carefully:

- Whether the nameplate model of frequency inverter are consistent with your order ratings. The box contains the frequency inverter, user manual.
- Whether the frequency inverter is damaged during transportation. If you find any omission or damage, please contact us or your local supplier immediately.

First-time Use

For the users who use this product for the first time, read the manual carefully. If in doubt concerning some functions or performances, contact the technical support personnel to ensure correct use.



Due to the continuous improvement of frequency inverter, this document will be updated without prior notice.

Table of Contents

1. Safety Information and Precautions	1
1.1 Safety Information.....	1
1.2 General Precautions.....	5
2. Product Information	9
2.1 Products Label and Model Designation	9
2.1.1 Product appearance.....	10
2.2 Technical Specifications	10
2.3 Model and Technical data.....	13
2.4 Product appearance and installation dimension.....	16
2.5 Daily maintenance of frequency inverters.....	19
2.6 Selection Guide of braking component.....	21
3. Installation	25
3.1 Installation environment.....	25
3.2 Installation direction and space.....	25
3.3 Peripheral Devices Connection Diagram	26
3.4 Instructions of Main Circuit Peripheral Devices	27
3.5 Model Selection of Main Circuit Peripheral Devices.....	28
3.6 Removal and mounting of operating panel and cover	30
3.7 Connection Terminals Diagram Description	32
3.8 Sketch and Description of Main Circuit Terminals	32
3.9 Cautions for Main Circuit Wiring	35
3.10 Control Circuit and Main Circuit Terminals Description	38
4. Operation and display	44
4.1 Instruction of operation and display.....	44
4.2 Viewing and Modifying Function Codes	46
4.3 Monitoring Status Parameters.....	46
4.4 Password Setting	47
4.5 Motor parameter auto-tuning	48
4.6 Function Code Table.....	49
4.7 Fault Alarm and Countermeasures	100
Appendix I Modbus communication protocol	110
Appendix II Dimension for special model/EM10.....	128



1. Safety Information and Precautions



In this manual, the notices are graded based on the degree of danger:



 Danger	Indicates that failure to comply with the notice will result in severe personal injury or even death.
 Warning	Indicates that failure to comply with the notice will result in personal injury or property damage.



Read this manual carefully so that you have a thorough understanding. Installation, commissioning or maintenance may be performed in conjunction with this chapter. EMHEATER will assume no liability or responsibility for any injury or loss caused by improper operation.

1.1 Safety Information

Before installation	 Danger	<ul style="list-style-type: none"> ● Do not use damaged or missing components frequency inverter. Failure to comply will result in personal injury. ● Please use the electric motor with upper B insulation class. Failure to comply will result in personal injury.
During installation	 Danger	<ul style="list-style-type: none"> ● Install the frequency inverter on incombustible objects such as metal, and keep it away from combustible materials. Failure to comply may result in a fire.

	 Warning	<ul style="list-style-type: none"> ● When two frequency inverters are laid in the same cabinet, arrange the installation positions properly to ensure the enough cooling effect. ● Do not drop wire residue or screw into the frequency inverter. Failure to comply will result in damage to the frequency inverter.
Wiring	 Danger	<ul style="list-style-type: none"> ● Wiring must be performed only by qualified personnel under instructions described in this manual. Failure to comply may result in unexpected accidents. ● A circuit breaker must be used to isolate the power supply and the frequency inverter. Failure to comply may result in a fire. ● Ensure that the power supply is cut off before wiring. Failure to comply may result in electric shock. ● Connect the frequency inverter to ground properly by standard. Failure to comply may result in electric shock.
	 Warning	<ul style="list-style-type: none"> ● Never connect the power supply cables to the output terminals (U, V, W) of the Frequency inverter. Failure to comply will result in damage to the frequency inverter. ● Make sure that all the connecting wires comply with the requirement of EMC and the safety standard in the region. Use wire sizes recommended in the manual. Failure to comply may result in accidents. ● Never connect the braking resistor between the DC bus terminals (P+) and (P-). Failure to comply may result in a fire.

Before power-on	 Danger	<ul style="list-style-type: none"> ● Check that the following requirements comply with: The voltage class of the power supply is consistent with the rated voltage class of the frequency inverter. The input terminals (R, S, T) and output terminals (U, V, W) are properly connected. No short-circuit exists in the peripheral circuit. The wiring is fastened. Failure to comply will result in damage to frequency inverter. ● Cover the frequency inverter properly before power-on to prevent electric shock.
Before power-on	 Warning	<ul style="list-style-type: none"> ● Do not perform the voltage resistance test on any part of the frequency inverter because such test has been done in the factory. Failure to comply will result in accidents. ● All peripheral devices must be connected properly under the instructions described in this manual. Failure to comply will result in accidents.
After power-on	 Danger	<ul style="list-style-type: none"> ● Do not open the frequency inverter's cover after power-on to prevent from electric shock. ● Do not touch the frequency inverter with wet hand and its peripheral circuit to prevent from electric shock. ● Do not touch the terminals of the frequency inverter (including the control terminals). Failure to comply may result in electric shock. ● Do not touch the U, V, W terminal or motor connecting terminals when frequency inverter automatically does safety testing for the external high-voltage electrical circuit. Failure to comply may result in electric shock.

	 Warning	<ul style="list-style-type: none"> ● Note the danger during the rotary running of motor when check the parameters. Failure to comply will result in accidents. ● Do not change the factory default settings of the frequency inverter. Failure to comply will result in damage to the frequency inverter.
During operation	 Danger	<ul style="list-style-type: none"> ● Do not go close to the equipment when selected the restart function. Failure to comply may result in personal injury. ● Do not touch the fan or the discharging resistor to check the temperature. Failure to comply will result in personal injury. ● Signal detection must be performed only by qualified personal during operation
	 Warning	<ul style="list-style-type: none"> ● Avoid objects falling into the frequency inverter when it is running. Failure to comply will result in damage to frequency inverter. ● Do not start/stop the frequency inverter by turning the contactor ON/OFF. Failure to comply will result in damage to the frequency inverter.

Maintenance	 Danger	<ul style="list-style-type: none">● Do not repair or maintain the frequency inverter at power-on. Failure to comply will result in electric shock.● Repair or maintain the frequency inverter only after the charge light on frequency inverter is powered off. This allows for the residual voltage in the capacitor to discharge to a safe value. Failure to comply will result in personal injury.● Repair or maintenance of the frequency inverter may be performed only by qualified personnel. Failure to comply will result in personal injury or damage to the frequency inverter.
--------------------	--	--

1.2 General Precautions

1.2.1 Motor insulation test

Perform the insulation test when the motor is used for the first time, or when it is reused after being stored for a long time, or in a regular check-up, in order to prevent the poor insulation of motor windings from damaging the frequency inverter. The motor must be disconnected from the frequency inverter during the insulation test. A 500-V mega-Ohm meter is recommended for the test. The insulation resistance must not be less than 5 M Ω .

1.2.2 Thermal protection of motor

If the rated capacity of the motor selected does not match that of the frequency inverter, especially when the frequency inverter's rated power is greater than the motor's, adjust the motor protection parameters on the operation panel of the frequency inverter or install a thermal relay in the motor circuit for protection.

1.2.3 Running at over 50 Hz

The frequency inverter provides frequency output from 0 to 3200 Hz with V/F mode (300 Hz is supported for frequency inverter running at FVC and SVC mode). If the frequency inverter is required to run at over 50 Hz, please consider the bearable capacity of the machine.

1.2.4 Vibration of mechanical device

The frequency inverter may encounter the mechanical resonance point at some output frequency points, which can be avoided by setting the skip frequency.

1.2.5 Motor heat and noise

The output of the frequency inverter is pulse width modulation (PWM) wave with certain harmonic frequencies, and therefore, the motor temperature, noise, and vibration are slightly greater than those motor runs at grid power frequency (50 Hz).

1.2.6 Voltage-sensitive device or capacitor at output side of the Frequency inverter

Do not install the capacitor for improving power factor or lightning protection voltage-sensitive resistor at the output side of the frequency inverter because the output of the frequency inverter is PWM wave. Otherwise, the frequency inverter may suffer transient over current and even to be damaged.

1.2.7 Contactor at the Input or Output side of the frequency inverter

When contactor is installed between the input side of the frequency inverter for the power supplying, the frequency inverter must not be started or stopped by the contactor switching on or off. If the frequency inverter has to be operated by the contactor, ensure that the time interval between switching is at least one hour. Since frequently charge and discharge will shorten the service life of the capacitor

inside of the frequency inverter.

When a contactor is installed between the output side of the frequency inverter and the motor, do not turn off the contactor when the frequency inverter is running. Otherwise, IGBT modules inside of frequency inverter may be damaged.

1.2.8 When input voltage is over rated voltage range

The frequency inverter must not be used over the allowable voltage range specified in this manual. Otherwise, the frequency inverter's components may be damaged. If required, please use a corresponding voltage transformer device.

1.2.9 Prohibition of three-phase input changed into two-phase input

Do not change the three-phase power input of the frequency inverter to two-phase input. Otherwise, frequency inverter will be damaged.

1.2.10 Surge suppressor

The frequency inverter has a built-in voltage sensitive resistor for suppressing the surge voltage. Using frequently surge place, please add extra surge voltage protection device at input side of frequency inverter.

Note: Do not add the surge suppressor at the output side of the frequency inverter.

1.2.11 Altitude and de-rating using

Where the altitude is above 1000 m and the cooling effect WEAKEN due to thin air, it is necessary to de-rate the power of frequency inverter. Please contact our company for technical supporting.

1.2.12 Some special application

If wiring that is not described in this manual such as shared DC bus is applied, please contact the agent or our company for technical supporting.

1.2.13 Scrap disposition

The electrolytic capacitors on the main circuit and PCB board may explode when they are burning. Poisonous gas is generated when the plastic parts are burning. Please treat them as industrial waste by special way.

1.2.14 Matched Motor

The standard matched motor is suitable four-pole squirrel-cage asynchronous induction motor. For other types of motor, please select a proper frequency inverter according to the rated motor current. If user uses inverter for permanent magnet synchronous motor, please contact my company for selecting another series inverter..

The cooling fan is coaxial to rotor shaft of non-variable-frequency motor, which will reduce cooling effect when the shaft rotational speed decreasing. If motor is required variable speed, add a separately cooling fan or replace motor to variable-frequency motor.

The common standard parameters of the matched motor have been configured inside the frequency inverter. It is still necessary to perform motor auto-tuning or modify the default values based on actual application. Otherwise, the running result and protection performance will be weaken.

The frequency inverter may alarm and even be damaged when short-circuit exists on cables or inside the motor. Therefore, perform insulation test when the motor and cables are newly installed or during routine maintenance. During the test, make sure the frequency inverter is disconnected from the tested parts.

2. Product Information

2.1 Products Label and Model Designation

EM10 - G 3 - 7d5 / P 3 - 011

① ② ③ ④ ② ③ ④

①	EM10 Series Frequency Inverter
② , ⑤	Products Type: G: General use P: Fan&Pump
③ , ⑥	Voltage range: 1: Single phase 220V 13: Single phase 220V to Three phase 380 2: Three phase 220V 3: Three phase 380V 4: Three phase 480V 5: Three phase 575V 6: Three phase 660V
④ , ⑦	Adaptable motor: 7d5: 7.5KW ;011: 11KW

2.1.1 Product appearance

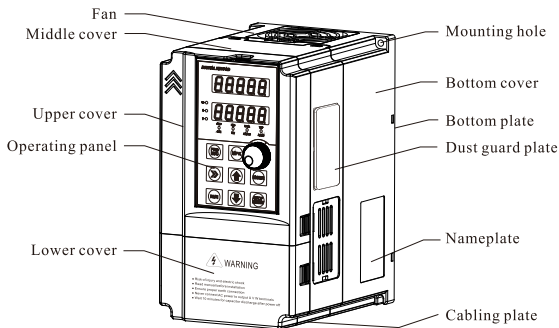

Diagram 2-1 Nameplate

The housing types of the EM10 models are listed in the following table:

	Plastic	Sheet metal
1PH 220V	0.75kW~2.2kW	--
3PH 220V	0.75kW~11kW	15kW~250kW
3PH 380V/480V	0.75kW~22kW	30kW~500kW

2.2 Technical Specifications

Input & Output

- **Input Voltage:** 220V/380V/480V/575V/660V±15%
- **Input Frequency:** 47~63Hz
- **Input Frequency Resolution:** 0.01Hz (Digital setting); maximum frequency×0.025% (Analog setting)
- **Output Voltage:** 0~Rated input voltage
- **Output Frequency:** 0~320Hz(SFC); 0~3200Hz (V/F)

Technical Performance

- **Control Mode:** Sensor-less vector control(SVC); Closed-loop vector control (FVC); Voltage/Frequency (V/F) control
- **Carrier Frequency:** 0.5kHz~16kHz
- **Startup Torque:** G type: 0.5Hz/150% (FVC); 0Hz/180%(FVC); P type: 0.5Hz/100%
- **Speed Range:**1:100(SVC);1:1000(FVC)
- **Speed Stability Accuracy:** $\pm 0.5\%$ (SVC); $\pm 0.02\%$ (FVC)
- **Torque Control Accuracy:** $\pm 5\%$ (FVC)
- **Overload Capacity:** G type:150% rated current 60s; 180% rated current 3s; P type: 120% rated current 60s;150% rated current 3s.
- **Torque Boost:** Auto boost; Manual boost 0.1%~30.0%
- **DC braking:** 0.00Hz~maximum frequency (DC braking frequency); 0.0s~36.0s(Braking time); 0.0%~100.0%(Braking trigger current value)

Individualized Functions

- **Built-in Simple PLC / Multiple Speeds:** It realizes up to 16 speeds via the simple PLC function or combination of DI terminal states.
- **Built-in PID:** It realizes closed loop control system easily.
- **Auto voltage regulation (AVR):** It can keep constant output voltage automatically when the mains voltage fluctuation
- **Overvoltage/ Overcurrent Stall Control:** The current and voltage are limited automatically during the running process so as to avoid frequently tripping due to overvoltage / over current.
- **Rapid Current Limit:** To avoid frequently over current faults of the frequency inverter.
- **Torque Limit and Control:** It can limit the torque automatically and prevent frequently over current tripping during the running process. Torque control can be implemented in the VC mode.

- **High Performance:** Control of asynchronous motor is implemented through the high-performance current vector control technology.
- **Virtual I/O:** Five groups of virtual DI/DO can realize simple logic control.
- **Timing Control:** Time range: 0.0~6500.0 minutes
- **Motor Overheat Protection:** The optional I/O extension card enables AI3 to receive the motor temperature sensor input (PT100, PT1000) so as to realize motor overheat protection.
- **Multiple Encoder Types:** It supports differential encoder, open-collector encoder
- **Protection Mode:** Motor short-circuit detection after power-on, input/output phase loss protection, over current and overvoltage protection, less voltage protection, overheat protection and overload protection,etc

External Interface

- **Running Command Giving:** key panel; Control terminals; Serial communication port; You can switch between these giving in various ways.
- **Frequency Giving:** There are 10 kinds frequency giving: digital setting, analog voltage setting, analog current setting, pulse setting and serial communication port setting.
- **Programmable Digital Input:** 6 digital input (DI) terminals, one of which supports up to 100 kHz high-speed pulse input
- **Programmable Analog Input:** 3 analog input (AI) terminals, AI1,AI2 support 0V~10 V or 0mA~20mA input, AI3 support -10V~+10V
- **Programmable Open Collector Output:** 1 FMP output terminal, that supports 0~100 kHz square wave signal output (Can be used as DO output)
- **Programmable Analog Output:**2 analog output (AO) terminals, both of them supports 0mA~20mA current output and 0V~10V voltage output.
- **Relay Output:** 2 relay output terminal (2.2KW and below only have 1

relay output terminal)

Environment

- **Installation Location:** Indoor, no direct sunlight, dust, corrosive gas, combustible gas, oil smoke, vapour, drip or salt.
- **Altitude:** Lower than 1000m
- **Ambient Temperature:** -10°C~ +40°C (de-rated if the ambient temperature is between 40°C and 50°C)
- **Humidity:** Less than 95%RH, without condensing
- **Vibration:** Less than 5.9 m/s² (0.6 g)
- **Storage Temperature:** -20°C ~ +60°C

2.3 Model and Technical data

Model	Power Capacity (KVA)	Input Current (A)	Output Current (A)	Adaptable Motor	
				KW	HP
Single phase 220V 50/60Hz					
EM10-G1-d75	1.5	8.2	4	0.75	1
EM10-G1-1d5	3	14	7	1.5	2
EM10-G1-2d2	4	23	9.6	2.2	3
Three phase 220V 50/60Hz					
EM10-G2-d75	3	5	3.8	0.75	1
EM10-G2-1d5	4	5.8	5.1	1.5	2
EM10-G2-2d2	5.9	10.5	9	2.2	3
EM10-G2-004	8.9	14.6	17	3.7	5
EM10-G2-5d5	17	26	25	5.5	7.5
EM10-G2-7d5	21	35	32	7.5	10
EM10-G2-011	30	46.5	45	11	15
EM10-G2-015	40	62	60	15	20
EM10-G2-018	57	76	75	18.5	25
EM10-G2-022	69	92	91	22	30

Model	Power Capacity (KVA)	Input Current (A)	Output Current (A)	Adaptable Motor	
				KW	HP
EM10-G2-030	85	113	112	30	40
EM10-G2-037	114	157	150	37	50
EM10-G2-045	134	180	176	45	60
EM10-G2-055	160	214	210	55	75
EM10-G2-075	231	307	304	75	100
Three phase 380V 50/60Hz					
EM10B-G3-d75/P3-1d5	1.5/3	5/5.8	2.1/3.8	0.75/1.5	1/2
EM10B-G3-1d5/P3-2d2	3/4	5.8/10.5	3.8/5.1	1.5/2.2	2/3
EM10B-G3-2d2/P3-004	4/5.9	10.5/14.6	5.1/9	2.2/3.7	3/5
EM10-G3-004/P3-5d5	5.9/8.9	14.6/20.5	9/13	3.7/5.5	5/7.5
EM10-G3-5d5/P3-7d5	8.9/11	20.5/26	13/17	5.5/7.5	7.5/10
EM10-G3-7d5/P3-011	11/17	26/35	17/25	7.5/11	10/15
EM10-G3-011/P3-015	17/21	35/38.5	25/32	11/15	15/20
EM10-G3-015/P3-018	21/24	38.5/46.5	32/37	15/18.5	20/25
EM10-G3-018/P3-022	24/30	46.5/62	37/45	18.5/22	25/30
EM10-G3-022/P3-030	30/40	62/76	45/60	22/30	30/40
EM10-G3-030/P3-037	40/57	76/92	60/75	30/37	40/50
EM10-G3-037/P3-045	57/69	92/113	75/91	37/45	50/60
EM10-G3-045/P3-055	69/85	113/128	91/112	45/55	60/75
EM10-G3-055/P3-075	85/114	128/157	112/150	55/75	75/100
EM10-G3-075/P3-090	114/134	157/180	150/176	75/90	100/125
EM10-G3-090/P3-110	134/160	180/214	176/210	90/110	125/150
EM10-G3-110/P3-132	160/192	214/256	210/253	110/132	150/200
EM10-G3-132/P3-160	192/231	256/307	253/304	132/160	200/250
EM10-G3-160/P3-200	231/250	307/385	304/377	160/200	250/280
EM10-G3-200/P3-220	250/280	385/430	377/426	200/220	280/300
EM10-G3-220/P3-250	280/355	430/468	426/465	220/250	300/370
EM10-G3-250/P3-280	355/396	468/525	465/520	250/280	370/400

Model	Power Capacity (KVA)	Input Current (A)	Output Current (A)	Adaptable Motor	
				KW	HP
EM10-G3-280/P3-315	396/445	525/590	520/585	280/315	400/420
EM10-G3-315/P3-355	445/500	590/665	585/650	315/355	420/500
EM10-G3-355	500	665	650	355	500
EM10-G3-400	560	785	725	400	530
EM10-G3-450	630	883	820	450	600
EM10-G3-500	800	920	860	500	660
Three phase 480V 50/60Hz					
EM10B-G4-d75/P4-1d5	1.5/3	5/5.8	2.1/3.8	0.75/1.5	1/2
EM10B-G4-1d5/P4-2d2	3/4	5.8/10.5	3.8/5.1	1.5/2.2	2/3
EM10B-G4-2d2/P4-004	4/5.9	10.5/14.6	5.1/9	2.2/3.7	3/5
EM10-G4-004/P4-5d5	5.9/8.9	14.6/20.5	9/13	3.7/5.5	5/7.5
EM10-G4-5d5/P4-7d5	8.9/11	20.5/26	13/17	5.5/7.5	7.5/10
EM10-G4-7d5/P4-011	11/17	26/35	17/25	7.5/11	10/15
EM10-G4-011/P4-015	17/21	35/38.5	25/32	11/15	15/20
EM10-G4-015/P4-018	21/24	38.5/46.5	32/37	15/18.5	20/25
EM10-G4-018/P4-022	24/30	46.5/62	37/45	18.5/22	25/30
EM10-G4-022/P4-030	30/40	62/76	45/60	22/30	30/40
EM10-G4-030/P4-037	40/57	76/92	60/75	30/37	40/50
EM10-G4-037/P4-045	57/69	92/113	75/91	37/45	50/60
EM10-G4-045/P4-055	69/85	113/128	91/112	45/55	60/75
EM10-G4-055/P4-075	85/114	128/157	112/150	55/75	75/100
EM10-G4-075/P4-090	114/134	157/180	150/176	75/90	100/125
EM10-G4-090/P4-110	134/160	180/214	176/210	90/110	125/150
EM10-G4-110/P4-132	160/192	214/256	210/253	110/132	150/200
EM10-G4-132/P4-160	192/231	256/307	253/304	132/160	200/250
EM10-G4-160/P4-200	231/250	307/385	304/377	160/200	250/280
EM10-G4-200/P4-220	250/280	385/430	377/426	200/220	280/300
EM10-G4-220/P4-250	280/355	430/468	426/465	220/250	300/370

Model	Power Capacity (KVA)	Input Current (A)	Output Current (A)	Adaptable Motor	
				KW	HP
EM10-G4-250/P4-280	355/396	468/525	465/520	250/280	370/400
EM10-G4-280/P4-315	396/445	525/590	520/585	280/315	400/420
EM10-G4-315/P4-355	445/500	590/665	585/650	315/355	420/500
EM10-G4-355	500	665	650	355	500
EM10-G4-400	560	785	725	400	530
EM10-G4-450	630	883	820	450	600
EM10-G4-500	800	920	860	500	660

2.4 Product appearance and installation dimension

2.4.1 Appearance and Installation Hole Dimension (mm)

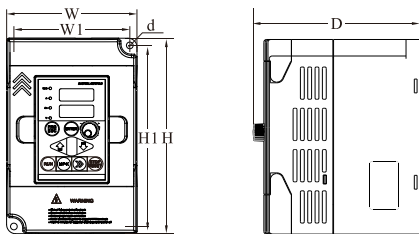

Diagram 2-2 EM10 0.75~2.2kW Wall-mounted installation dimensions

Matching inverter		Appearance and installing dimension (Unit: mm)					
Voltage	Power range	W	W1	H	H1	D	d
1PH/3PH 220V	0.75~2.2kW	101	90	152	141	132	Φ4
3PH 380V/480V	0.75~2.2 kW						

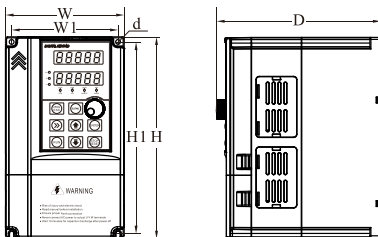

Diagram 2-3 EM10 4~22kW Wall-mounted installation dimensions

Matching inverter		Appearance and installing dimension (Unit: mm)					
Voltege	Power	W	W1	H	H1	D	d
3PH 380V/480V	4~5.5kW	120	108	205	195	166	Φ4.5
3PH 220V	4~5.5kW	162	148	250	238	191	Φ5.5
3PH 380V/480V	7.5~11kW						
3PH 220V	7.5~11kW	223	207	323	307	207	Φ5.5
3PH 380V/480V	15~22kW						

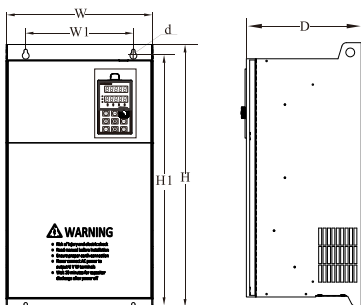

Diagram 2-4 EM10 30~500kW Wall-mounted installation dimensions

Matching inverter		Appearance and installing dimension (Unit: mm)					
Voltege	Power Range	W	W1	H	H1	D	d
3PH 220V	15~18.5kW	275	170	435	410	235	Φ8
3PH 380V/480V	30~37kW						
3PH 220V	22~30kW	300	220	470	435	258	Φ10
3PH 380V/480V	45~55kW						
3PH 220V	37~45kW	335	285	490	465	258	Φ10
3PH 380V/480V	75~90kW						
3PH 220V	55kW	410	260	610	575	280	Φ12
3PH 380V/480V	110kW						
3PH 220V	75kW	475	320	720	675	335	Φ12
3PH 380V/480V	132~200kW						
3PH 380V/480V	220~280kW	535	360	885	830	370	Φ12

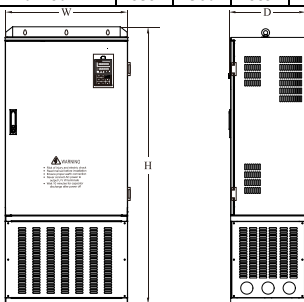

Diagram 2-5 EM10 315~560kW Floor-mounted installation dimensions

Matching inverter		Appearance and installing dimension (Unit: mm)					
Voltege	Power Range	W	W1	H	H1	D	d
3PH 380V/480V	315~355kW	535	360	1130	830	370	Φ12
3PH 380V/480V	400~560kW	650	360	1300	990	415	Φ12

Note: Please refer to Appendix II for inverter EM10-G13 /EM10 series dimensional information

2.4.2 Appearance and installation dimension of external keypad (keypad tray)

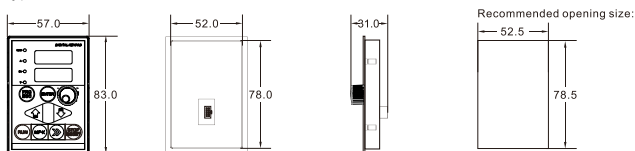

Diagram 2-6 Appearance and installation dimension of small size external keypad

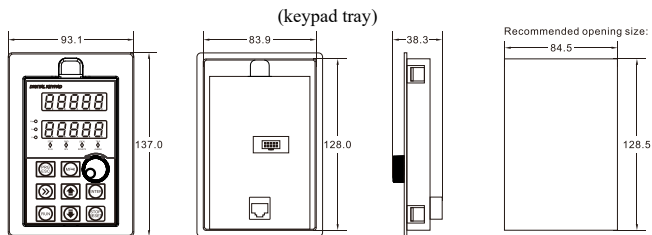

Diagram 2-7 Appearance and installation dimension of big size external keypad
(keypad tray)

2.5 Daily maintenance of frequency inverters

2.5.1 Daily maintenance

Due to the influence of temperature, humidity, dust and vibration, it will lead to poor heat dissipation and component aging of frequency inverter, and results in potential failure or reducing the service life of frequency inverter. Therefore, it is necessary to do daily and regular maintenance of the frequency inverter.

Daily check items:

1. Check if the frequency inverter sound is normal during the running of the motor;
2. Check if there is a vibration during the running of the motor;
3. Check whether the installation environment of frequency inverter has changed;
4. Check if the cooling fan of frequency inverter is working correctly, the cooling air duct is clear;
5. Check if the frequency inverter is overheating;
6. Make sure that the frequency inverter should always be kept in a clean state;
7. Clear up effectively the dust on the surface of the frequency inverter, prevent the dust from entering into the inside of the frequency inverter, especially for the metal dust;
8. Clear up effectively the oil and dust on the cooling fan of frequency inverter.

2.5.2 Regular inspection

Please regularly check frequency inverter, especially for the difficult checking place during running.

Regular inspection items:

1. Check the air duct and clear up regularly;
2. Check if there are any loose screws;
3. Check if the inverter has been corroded;
4. Check whether the wiring terminals show signs of arcing.

Note: When using the megger(please use the DC 500V meg ohm meter) to measure the insulation resistance, you shall disconnect the main circuit to the frequency inverter. Do not use the insulation resistance meter to test the control circuit. Do not to do the high voltage test (It has been done when the frequency inverter producing in factory.)

2.5.3 Replacement of wearing parts

The vulnerable parts of frequency inverter include the cooling fan and filter electrolytic capacitor, its service life is closely related to the using environment and maintenance status. The general service life is:

Part Name	Service Life
Fan	3 to 4 Years
Electrolytic capacitor	5 to 6 Years

The user can confirm the replace time according to the running time.

1. Possible reasons for the damage of cooling fan: bearing wear and blade aging. Distinguish standard: Any cracks in the fan blade, any abnormal vibration sound during the starting of frequency inverter.
2. Possible reasons for the damage of filtering electrolytic capacitor: poor quality of the input power supply, the environment temperature is higher, the load change frequently and the electrolyte aging. Distinguish standard: Any leakage of its liquid, if the safety valve is protruding, please test capacitor electrostatic capacitance and insulation resistance.

2.5.4 Storage of the frequency inverter

After buying the frequency inverter, users shall pay attention to the temporary and long-term storage as following:

1. Store the frequency inverter in the original packaging;
2. Long-term storage can lead to the degradation of electrolytic capacitors, and must ensure to power on for once within 2 years. And the power-on time is at least 5 hours. The input voltage must slowly rise to the rating by using the voltage regulator.

2.6 Selection Guide of braking component

Table 2-5 is the recommended value of braking resistor, users can select the different resistance value and power according to the actual situation,(but the resistance value must not be less than the recommended value in the table, and the power can be bigger.) The selection of braking resistance need to be confirmed according to the power that the motor generated in the practical

application systems, and is relevant to the system inertia, deceleration time, the energy of the potential energy load, needs customers to choose according to actual situation. The greater the inertia and the shorter deceleration time is needed more frequently braking, so the braking resistor needs the one with bigger power but smaller resistance value.

2.6.1 Selection of braking resistance value

When braking, almost all the regenerated energy of motor is consumed by the braking resistor.

According to the formula: $U \cdot U/R = P_b$

In the formula:

U --- The braking voltage when the system brake stably (different system is different, for the 380VAC system generally take 700V)

R - Braking resistor value

P_b – Power of braking(W)

2.6.2 Selection power of braking resistor

In theory the power of braking resistor is consistent with the braking power, but it need to be taken into consideration that the braking resistor power will derate to 70%.

According to the formula: $0.7 \cdot P_r = P_b \cdot D$

In this formula:

P_r ----Power of resistor

D---- Braking proportion (the proportion that the regeneration process accounts for the whole process)

Elevator---- 20%~30%

Uncoiling and coiling machine---- 20%~30%

Centrifugal machine---- 50%~60%

Occasionally braking load---- 5%

Other machine generally----10%

Table 2-5 EM10 Inverter braking components selection table

Inverter Power	Recommend braking resistor		Braking unit	Remark
	Power	Resistance		
Single phase 220V				
EM10-G1-d75	80W	$\geq 150\Omega$	Built-in as standard	No special instructions
EM10-G1-1d5	100W	$\geq 100\Omega$		
EM10-G1-2d2	100W	$\geq 70\Omega$		
Three phase 220V				
EM10-G2-d75	150W	$\geq 110\Omega$	Built-in as standard	No special instructions
EM10-G2-1d5	250W	$\geq 100\Omega$		
EM10-G2-2d2	300W	$\geq 65\Omega$		
EM10-G2-004	400W	$\geq 45\Omega$		
EM10-G2-5d5	800W	$\geq 22\Omega$		
EM10-G2-7d5	1000W	$\geq 16\Omega$	External	No special instructions
EM10-G2-011	1500W	$\geq 11\Omega$		
EM10-G2-015	2500W	$\geq 8\Omega$		
EM10-G2-018	3.7 kW	$\geq 8.0\Omega$		
EM10-G2-022	4.5 kW	$\geq 8\Omega$		
EM10-G2-030	5.5 kW	$\geq 4\Omega$		
EM10-G2-037	7.5 kW	$\geq 4\Omega$		
EM10-G2-045	4.5kW×2	$\geq 4\Omega \times 2$		
EM10-G2-055	5.5kW×2	$\geq 4\Omega \times 2$		
EM10-G2-075	16kW	$\geq 1.2\Omega$		
Three phase 380V/480V				
EM10B-G3[4]-d75/P3[4]-1d5	150W	$\geq 300\Omega$	Built-in as standard	No special instructions
EM10B-G3[4]-1d5/P3[4]-2d2	150W	$\geq 220\Omega$		
EM10B-G3[4]-2d2/P3[4]-004	250W	$\geq 200\Omega$		
EM10-G3[4]-004/P3[4]-5d5	300W	$\geq 130\Omega$		
EM10-G3[4]-5d5/P3[4]-7d5	400W	$\geq 90\Omega$		
EM10-G3[4]-7d5/P3[4]-011	500W	$\geq 65\Omega$		
EM10-G3[4]-011/P3[4]-015	800W	$\geq 43\Omega$		
EM10-G3[4]-015/P3[4]-018	1000W	$\geq 32\Omega$		
EM10-G3[4]-018/P3[4]-022	1300W	$\geq 25\Omega$		
EM10-G3[4]-022/P3[4]-030	1500W	$\geq 22\Omega$	External	No special instructions
EM10-G3[4]-030/P3[4]-037	2500W	$\geq 16\Omega$		
EM10-G3[4]-037/P3[4]-045	3.7 kW	$\geq 16.0\Omega$		
EM10-G3[4]-045/P3[4]-055	4.5 kW	$\geq 16\Omega$		
EM10-G3[4]-055/P3[4]-075	5.5 kW	$\geq 8\Omega$		
EM10-G3[4]-075/P3[4]-090	7.5 kW	$\geq 8\Omega$		

Inverter Power	Recommend braking resistor		Braking unit	Remark
	Power	Resistance		
EM10-G3[4]-090/P3[4]-110	4.5kW×2	≥ 8Ω×2		
EM10-G3[4]-110/P3[4]-132	5.5kW×2	≥ 8Ω×2		
EM10-G3[4]-132/P3[4]-160	6.5kW×2	≥ 8Ω×2		
EM10-G3[4]-160/P3[4]-200	16kW	≥ 2.5Ω		
EM10-G3[4]-200/P3[4]-220	20 kW	≥ 2.5Ω		
EM10-G3[4]-220/P3[4]-250	22 kW	≥ 2.5Ω		
EM10-G3[4]-250/P3[4]-280	12.5kW×2	≥ 2.5Ω×2		
EM10-G3[4]-280/P3[4]-315	14kW×2	≥ 2.5Ω×2		
EM10-G3[4]-315/P3[4]-355	16kW×2	≥ 2.5Ω×2		
EM10-G3[4]-355	17kW×2	≥ 2.5Ω×2		
EM10-G3[4]-400	14 kW×3	≥ 2.5Ω×3		
EM10-G3[4]-450	16 kW×3	≥ 2.3Ω×3		

2.6.3 Braking resistor connection description

The braking resistor connection of EM10 series frequency inverter is showed as below:

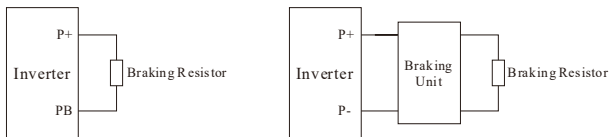

Diagram 2-8 Braking resistor connection scheme

3. Installation

3.1 Installation environment

1. The place with indoor vents or ventilation devices.
2. The environment temperature shall be $-10^{\circ}\text{C}\sim 40^{\circ}\text{C}$. If the temperature is over 40°C but less than 50°C , better to take down the cover of frequency inverter or open the front door of cabinet to facilitate heat dissipation.
3. Try to avoid high temperature and wet place; the humidity shall be less than 90% without frost deposit.
4. Avoid direct sunlight.
5. Keep away from flammable, explosive and corrosive gas and liquid.
6. No dust, floating fiber and metal particles.
7. Install on the place without strongly vibration. And the vibration should be not over 0.6G, please pay attention to far away from the punching machine, etc.
8. Keep away from electromagnetic interference source.

3.2 Installation direction and space

In order to not affect the service life of frequency inverter and reduce its performance, note for its installation direction and space and correctly fasten it.

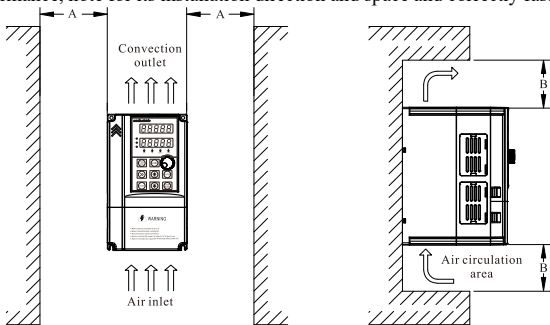

Diagram3-1 Ventilating duct installation dimension diagram of frequency inverter

Power class	Installation dimension	
	A	B
$\leq 7.5\text{kW}$	$\geq 20\text{mm}$	$\geq 100\text{mm}$
11kW - 30kW	$\geq 50\text{mm}$	$\geq 200\text{mm}$
$\geq 37\text{kW}$	$\geq 50\text{mm}$	$\geq 300\text{mm}$

Please install the frequency inverter vertically, to dissipate heat upward, and pay attention to direction of frequency inverter to avoid inversion.

If there are several units of frequency inverter installed in one cabinet, please install them side by side, do not to install up and down.

3.3 Peripheral Devices Connection Diagram

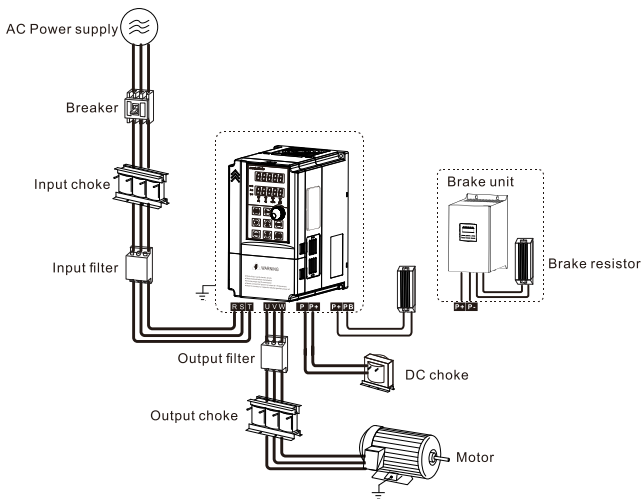

Diagram 3-2 Peripheral Devices Connection

3.4 Instructions of Main Circuit Peripheral Devices

Table 3-1 Main circuit peripheral devices use instructions

Parts Name	Function Description
MCCB	<p>Installation Location: Front of input circuit</p> <p>The capacity of the circuit breaker shall be 1.5 to 2 times of the rated current of the inverter.</p> <p>The protect time of the circuit breaker shall fully consider the time features of the inverter overload protection.</p>
Residual-current circuit breaker (RCCB)	<p>Installation Location: Front of input circuit</p> <p>As the inverter output is the high-frequency pulse output, there will be high-frequency leakage current. Special leakage circuit breaker shall be used when installing leakage circuit breaker at the input side of the inverter.</p> <p>It is suggested that B type leakage circuit breaker be used, and the leakage current value shall be set as 300mA.</p>
Input AC reactor or DC reactor	<p>Installation Location: Frequency inverter input side / near the frequency inverter</p> <p>The inverter power supply capacity is more than 600kVA or 10 times of the inverter capacity.</p> <p>If there is switch type reactive-load compensation capacitor or load with silicon control at the same power, there will be high peak current flowing into input power circuit, causing the damage of the rectifier of frequency inverter.</p> <p>When the voltage unbalancedness of the three-phase power supply of the inverter exceeds 3%, the rectifier component will be damaged.</p> <p>It is required that the input power factor of the inverter shall be higher than 90%.</p> <p>When the above situations occurred, install the AC reactor at the input side of the inverter or DC reactor to the DC reactor terminal.</p>
Input noise filter	<p>Installation Location: The frequency inverter input side</p> <p>To reduce the noise input from the power to the inverter or output from</p>

	the inverter to the power.
Thermal protection relay	Installation Location: The output side of frequency inverter Although the inverter has motor overload protection function, when one inverter drives two or more motors or multi-pole motors, to prevent the motor over-temperature failure, thermal protection relay shall be installed between the inverter and each motor.
Output filter	Installation Location: The output side of frequency inverter When the output side of the inverter is connected with output filter, the conduction and radiation interference can be reduced.
Output AC reactor	Installation Location: Between the output side of frequency inverter and motor, near the frequency inverter When the cable connecting the inverter and the motor is longer than 50 meters, it is suggested to install AC output reactor to suppress the high-frequency oscillation to avoid the damage to motor insulation, large leakage current and frequent inverter protective action.

3.5 Model Selection of Main Circuit Peripheral Devices

Table 3-2 Model Selection Diagram of Main Circuit Peripheral Devices
(Recommended)

Frequency inverter Model	MCCB (A)	Contactor (A)	Main Circuit		Control Circuit (mm2)
			Input side (mm2)	Output side (mm2)	
Single-phase 220V					
EM10-G1-d75	16	10	2.5	2.5	1.0
EM10-G1-1d5	20	16	4.0	2.5	1.0
EM10-G1-2d2	32	20	6.0	4.0	1.0
Three-phase 220V					
EM10-G2-d75	16	10	2.5	2.5	1.0
EM10-G2-1d5	16	10	2.5	2.5	1.0
EM10-G2-2d2	25	16	4.0	4.0	1.0

Frequency inverter Model	MCCB (A)	Contactor (A)	Main Circuit		Control Circuit
			Input side	Output side	
			(mm2)	(mm2)	(mm2)
EM10-G2-004	32	25	4.0	4.0	1.0
EM10-G2-5d5	63	40	4.0	4.0	1.0
EM10-G2-7d5	63	40	6.0	6.0	1.0
EM10-G2-011	100	63	10	10	1.0
EM10-G2-015	125	100	16	10	1.0
EM10-G2-018	160	100	16	16	1.0
EM10-G2-022	200	125	25	25	1.0
EM10-G2-030	200	125	35	25	1.0
EM10-G2-037	250	160	50	35	1.0
EM10-G2-045	250	160	70	35	1.0
EM10-G2-055	350	350	120	120	1.0
EM10-G2-075	500	400	185	185	1.0
Three-phase 380V					
EM10B- G3-d75/P3-1d5	10	10	2.5	2.5	1.0
EM10B- G3-1d5/P3-2d2	16	10	2.5	2.5	1.0
EM10B-G3-2d2/P3-004	16	10	2.5	2.5	1.0
EM10-G3-004/P3-5d5	25	16	4.0	4.0	1.0
EM10-G3-5d5/P3-7d5	32	25	4.0	4.0	1.0
EM10-G3-7d5/P3-011	40	32	4.0	4.0	1.0
EM10-G3-011/P3-015	63	40	4.0	4.0	1.0
EM10-G3-015/P3-018	63	40	6.0	6.0	1.0
EM10-G3-018/P3-022	100	63	6	6	1.0
EM10-G3-022/P3-030	100	63	10	10	1.0
EM10-G3-030/P3-037	125	100	16	10	1.0
EM10-G3-037/P3-045	160	100	16	16	1.0
EM10-G3-045/P3-055	200	125	25	25	1.0
EM10-G3-055/P3-075	250	125	35	25	1.0
EM10-G3-075/P3-090	250	160	50	35	1.0

Frequency inverter Model	MCCB (A)	Contactor (A)	Main Circuit		Control Circuit
			Input side	Output side	
			(mm ²)	(mm ²)	(mm ²)
EM10-G3-090/P3-110	350	160	70	35	1.0
EM10-G3-110/P3-132	350	350	120	120	1.0
EM10-G3-132/P3-160	400	400	150	150	1.0
EM10-G3-160/P3-200	500	400	185	185	1.0
EM10-G3-200/P3-220	630	600	150*2	150*2	1.0
EM10-G3-220/P3-250	630	600	150*2	150*2	1.0
EM10-G3-250/P3-280	800	600	185*2	185*2	1.0
EM10-G3-280/P3-315	800	800	185*2	185*2	1.0
EM10-G3-315/P3-355	1000	800	150*3	150*3	1.0
EM10-G3-355/P3-400	1000	800	150*4	150*4	1.0
EM10-G3-400/P3-450	1200	1000	150*4	150*4	1.0
EM10-G3-450--	1200	1200	150*4	150*4	1.0

3.6 Removal and mounting of operating panel and cover

3.6.1 Removal and mounting of operating panel (keypad)

The operating panel of EM10 series frequency inverter is a plug type, If you need to take it off when use or maintenance, please make sure the gentle actions, or it is easy to damage the plug type connection terminals on operating panel.

The removal and mounting of operating panel (keypad) is showed as Diagram3-3 and Diagram3-4:

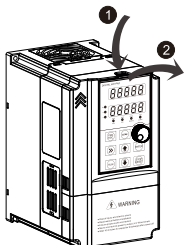

Diagram 3-3 Removal of operating panel(keypad)

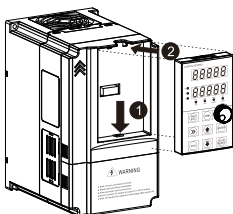

Diagram 3-4 Mounting of operating panel (keypad)

3.6.2 Removal and Mounting of Frequency Inverter

The EM10 series frequency inverter below 22kw (380V) uses plastic case. The removal and mounting of upper cover refers Diagram3-5. Please use tool to push the hooks on both side of lower cover.

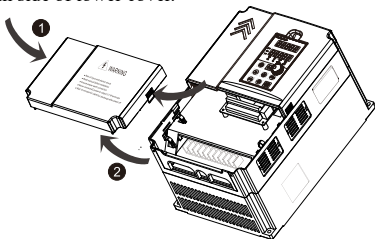

Diagram 3-5 The cover removal of plastic case

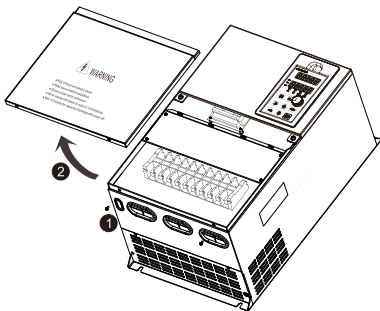

Diagram 3-6 The cover removal of sheet metal case

3.7 Connection Terminals Diagram Description

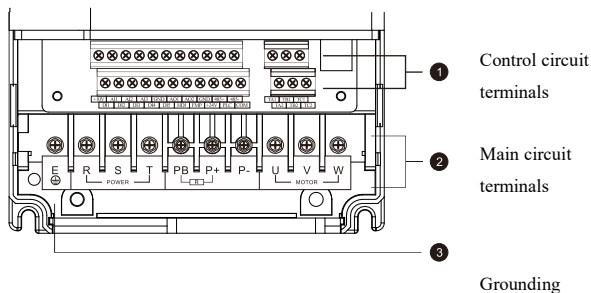
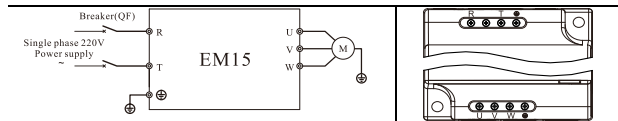

Diagram 3-7 EM10 Series terminal distribution diagram

3.8 Sketch and Description of Main Circuit Terminals

3.8.1 Function and description of Main Circuit Terminals

Single phase 220V: EM10-G1-d75 ~ EM10-G1-2d2



Three phase 220V: EM10-G2-d75 ~ EM10-G2-2d2

Three phase 380V: EM10B-G3-d75/P3-1d5 ~ EM10B-G3-2d2/P3-004

Three phase 480V: EM10B-G4-d75/P4-1d5 ~ EM10B-G4-2d2/P4-004

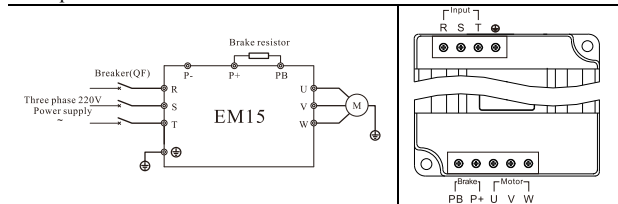

Three phase 220V: EM10-G2-004 ~ EM10-G2-011

Three phase 380V: EM10-G3-004/P3-5d5 ~ EM10-G3-022/P3-030

Three phase 480V: EM10-G4-004/P4-5d5 ~ EM10-G4-022/P4-030

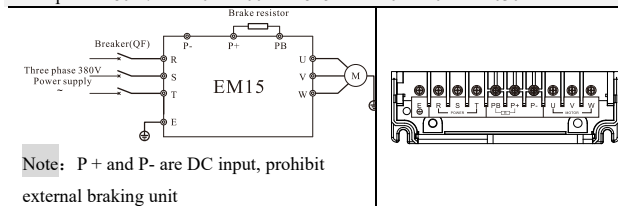

Three phase 220V: EM10-G2-015 ~ EM10-G2-045

Three phase 380V: EM10-G3-030/P3-037 ~ EM10-G3-090/P3-110

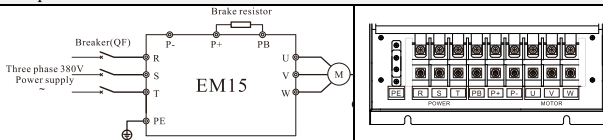
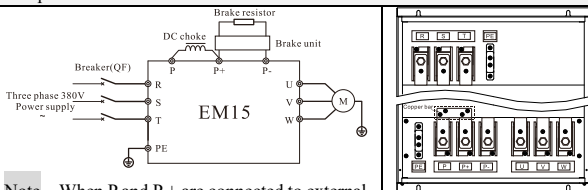
Three phase 480V: EM10-G4-030/P4-037 ~ EM10-G4-090/P4-110

Three phase 220V: EM10-G2-055 ~ EM10-G2-075
Three phase 380V: EM10-G3-110/P3-132~ EM10-G3-560
Three phase 480V: EM10-G4-110/P4-132 ~ EM10-G4-560

Note: When P and P+ are connected to external DC reactors, the internal short-circuited copper bars need to be removed

Terminal symbol	Function description
L,N or R,T	Single-phase AC power input terminals
R,S,T	Three-phase AC power input terminals
P+,PB	Braking resistor connection
P,P+	External DC reactor connecting terminals-shortcd by bronze before delivery
P+,P-	DC power input terminals; External brake unit DC output terminal
 or E/PE	Grounding terminal

Terminal symbol	Function description
U,V,W	Three-phase AC power output terminals

Note: Below 22kW with standard built-in unit can realize DC bus and braking function at the same time, if upper 30kW external DC reactor and braking function is needed, please contact the manufacturer.

3.9 Cautions for Main Circuit Wiring

3.9.1 Power Supply Wiring

- It is forbidden to connect the power cable to the inverter output terminals, otherwise, the internal components of the inverter will be damaged.
- To facilitate the input side over current protection and power off maintenance, the inverter shall connect to the power supply through the circuit breaker or leakage circuit breaker and contactor.
- Please confirm that the power supply phases, rated voltage are consistent with that of the nameplate, otherwise, the inverter may be damaged.

3.9.2 Motor Wiring

If the cable between the inverter and the motor is too long, the higher harmonic leakage current of the output will produce by cable length, which will lead to adverse impact on the inverter and the peripheral devices. It is suggested that when the motor cable is longer than 100m, add AC reactor at output side. Refer to the following table for the cable length and carrier frequency setting.

Length of cable between the inverter and motor	Carrier frequency (d6-00)
Less than 50m	Less than 15kHz
Less than 100 m	Less than 10kHz
More than 100m	Less than 5kHz

3.9.3 Grounding Wiring

- The inverter will produce leakage current. The higher the carrier frequency is, the larger the leakage current will be. The leakage current of the inverter is more than 3.5mA, and the exact value of the leakage current is determined by the using conditions. To ensure the safety, the inverter and the motor must be reliably grounded.
- The grounding resistance shall be less than 10ohm. For the grounding wire diameter requirement as IEC standard.
- Do not share grounding wire with the welding machine and other power equipment.
- In the applications with more than 2 inverters, keep the grounding wire out from forming a loop.

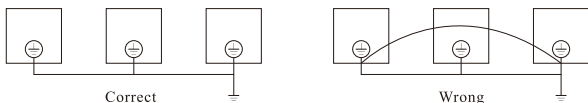

Diagram 3-8 Grounding Wire Connection Sketch Map

3.9.4 Solution for Conduction and Radiation Interference

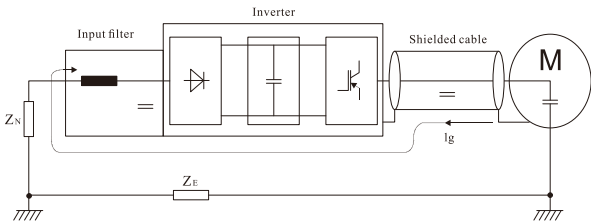

Diagram 3-9 Connection of conduction and radiation interference solutions

- When the input noise filter is installed, the cable connecting the filter to the inverter input power side shall be as short as possible.
- The filter case and mounting cabinet shall be reliably grounded in large area to reduce the back flow impedance of the noise current I_g .

- The cable connecting the inverter and the motor shall be as short as possible. The motor cable adopts 4-core cable, The cable grounding end grounded at the inverter side, the other end connected to the motor case. The motor cable shall be sleeved into the metal tube.
- The input power cable and output motor cable shall be kept away from each other as far as possible.
- The equipment and signal cables vulnerable to influence shall be kept far away from the inverter.
- Key signal cables shall adopt shielding cable. It is suggested that the shielding layer shall be grounded with 360-degree grounding method and sleeved into the metal tube. The signal cable shall be kept far away from the inverter input cable and output motor cable. If the signal cable must cross the input cable and output motor cable, they shall be kept orthogonal.
- When analog voltage and current signals are adopted for remote frequency setting, twinning shielding cable shall be used. The shielding layer shall be connected to the grounding terminal PE of the inverter, and the signal cable shall be no longer than 50m.
- The cables of the control circuit terminals TA/TB/TC and other control circuit terminals shall be separately routed.
- It is forbidden to short circuit the shielding layer and other signal cables and the equipment.
- When the inverter is connected to the inductive load equipment (e.g. electromagnetic contactor, relay and solenoid valve), surge suppressor must be installed on the load equipment coil, as showed in Diagram 3-10

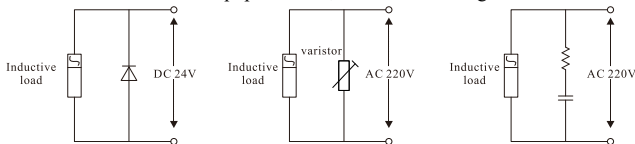

Diagram 3-10 Application example of inductive load surge suppressor

3.10 Control Circuit and Main Circuit Terminals Description

3.10.1 Control Circuit and Main Circuit Wiring

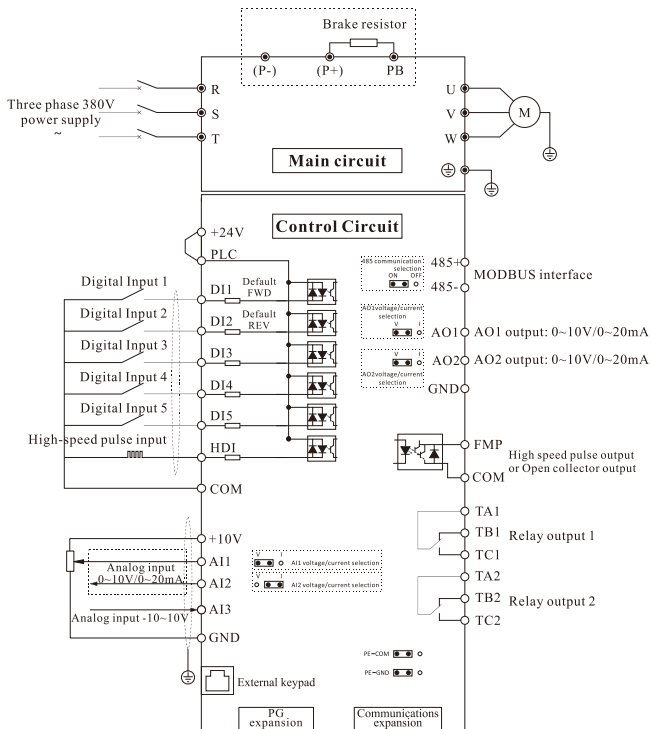

Diagram 3-11 Control Circuit and Main Circuit Wiring

3.10.2 Control Circuit Terminal Layout

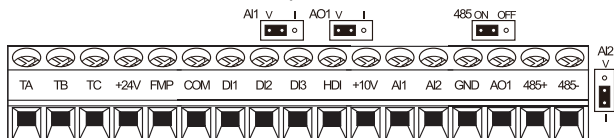

Diagram 3-12 Single/Three phase 0.75~2.2kW Control Circuit Terminal Sketch Map

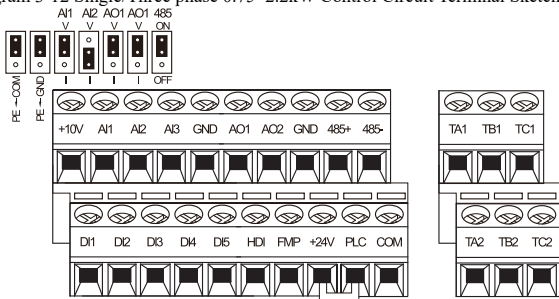

Diagram 3-13 Three phase 4Kw and above Control Circuit Terminal Sketch Map

3.10.3 Description of control circuit terminals

Table 3-3 Description of control circuit terminals

Type	Terminal Symbol	Terminal Name	Terminal function description
Power Supply	+10V-GND	External +10V power supply	Provide +10V power supply to external unit. Maximum output current:10mA Generally, it provides power supply to external potentiometer with resistance range of 1 k Ω ~10k Ω
	+24V-COM	External +24V power supply	Provide +24 V power supply to external unit. Generally, it provides power supply to DI/DO terminals and external sensors. Maximum output current: 200 mA

Type	Terminal Symbol	Terminal Name	Terminal function description
	PLC	External power supply input terminals	It connect with +24V terminal by default
Analog input	AI1-GND	Analog input 1	1. Input range: DC 0V~10V/0mA~20mA(decided by jumper AI1/AI2 on the control board); AI3: DC -10V~+10V 2. Impedance: 22 k Ω (voltage input), 500 Ω (analog current input)
	AI2-GND	Analog input 2	
	AI3-GND	Analog input 3	
Digital input	DI1-COM	Digital input 1	1. Optical coupling isolation, option dual polarity input 2. Input Impedance: 2.4 k Ω 3. Voltage range of level input: 9V~30 V
	DI2-COM	Digital input 2	
	DI3-COM	Digital input 3	
	DI4-COM	Digital input 4	
	DI5-COM	Digital input 5	
	HDI-COM	High Speed Pulse Input	Maximum input frequency: 100 kHz (Also can be used as DI)
Analog output	AO1-GND	Analog output 1	Voltage or current output type is decided by jumper AO1/AO2. Output voltage range: 0V~10 V Output current range: 0mA~20 mA
	AO2-GND	Analog output 2	

Type	Terminal Symbol	Terminal Name	Terminal function description
	FMP-COM	High Speed Pulse Output	Constrained by function code b4-00 "FMP terminal output mode selection" as the high-speed pulse output, the highest frequency is 100kHz; when use as an open collector output, specifications is the same as DO.
Relay output	TA-TB	NC terminal	Contact driving capacity: 250 Vac, 3 A, $\text{COS}\phi = 0.4$ 30 Vdc, 1 A
	TA1/2-TB1/2		
	TA-TC	NO terminal	
	TA1/2-TC1/2		
RS485 Output	485+	Communication port terminal	Input and output signal terminals for MODBUS protocol communication
	485-		
Auxiliary interface	PG card interface		PG cards: Open-collector, differential are selectable options.
	Communications expansion		Reversed
	External keypad interface		Connected to an extending keypad
Jumper	PE-COM		COM grounding PE selection, default connected. In the meeting of interference, connecting PE to COM can improve anti-interference
	PE-GND		GND grounding PE selection, default connected. In the meeting of interference, connecting PE to COM can improve anti-interference ability.
	AI1		AI1 output type selection. Voltage or Current output, voltage output by default.
	AI2		AI2 output type selection.

Type	Terminal Symbol	Terminal Name	Terminal function description
			Voltage or Current output, current output by default.
		AO1	AO1 output type selection. Voltage or Current output, voltage output by default.
		AO2	AO2 output type selection. Voltage or Current output, voltage output by default.
		485	485 communication resistor selection, default connection ON. In the case of interference, anti-interference can be improved.

3.10.4 Wiring of Analog Input Terminals

When the voltage signal is used as analog input, it is vulnerable from outside interference. Please use shielding cable, and ensure that the shielding cable reliably connect to the grounding. The cable should be as short as possible, and keep away from power lines. In serious interference occasions, you might consider to add a filter capacitor or ferrite core ring in signal cable.

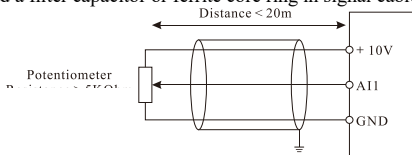
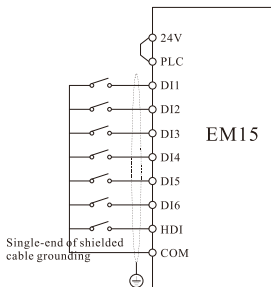

Diagram 3-14 Wiring of analog input terminals

3.10.5 Wiring of Digital Input Terminals

DI wiring mode 1 (Factory default wiring mode): The external power supply is not used when DI is set as NPN mode.



DI wiring mode 2: The external power supply is used when DI is set as NPN mode.

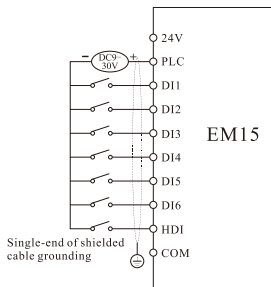

Diagram 3-15 Wiring of digital input terminals in two different modes

4. Operation and display

4.1 Instruction of operation and display

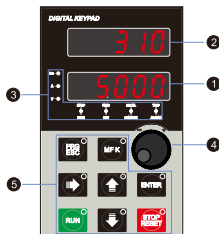









Diagram 4-1 Operating Keypad

No.	Name	Function	
①	Main LED display area	The 5-digit LED display is able to display the setting frequency, output frequency, monitoring data and Error codes.	
②	Auxiliary LED display area	The 5-digit LED display is able to display various operating status information, such as the running frequency, the setting frequency, output voltage and so on.	
③	Unit / Status Indicator area	Hz	Frequency unit
		A	Current unit
		V	Voltage unit
		STOP/ RUN	OFF indicates that the frequency inverter is in the stop state and ON indicates that the frequency inverter is in the running state.
		FWD/REV	It is Forward/Reverse indicator, ON indicates reverse rotation.
	LOCAL /REMOTE	It indicates whether the frequency inverter is operated by operation keypad, terminals or communication. OFF indicates keypad	

			operation control state; ON indicates terminals operation control state; Blinking indicates communication operation control state.
		TRIP /ALARM	Tuning/ Torque Control/Fault indicator When the indicator is ON, it indicates torque control mode. When the indicator is blinking slowly, it indicates the auto-tuning state. When the indicator is blinking quickly, it indicates the error state.
4	Encoder knob	Frequency, data or function code increase or decrease; the encoder knob has the confirmation key function	
5	Operation key area		Programming key: Enter or exit menu level I.
			Confirmation key: Enter the menu interfaces level by level, and confirm the parameter setting.
			Multi-function key: Perform function switchover according to the setting of b9-01
			Shift key: Select the displayed parameters in turn in the stop or running state, and select the digit to be modified when modifying parameters.
			Increment key: Increase data or function code.
			Decrement key: Decrease data or function code.
			Running key: Start the frequency inverter in the keypad control mode.
			Stop/Reset key: Stop the frequency inverter when it is in the running state and perform the reset operation when it is in the error state. The functions of this key are restricted by b9-00.

4.2 Viewing and Modifying Function Codes

The operation panel of the EM10 adopts three-level menu.

The three-level menu consists of function code group (Level I), function code (Level II), and function code setting value (level III), as shown in the following figure.

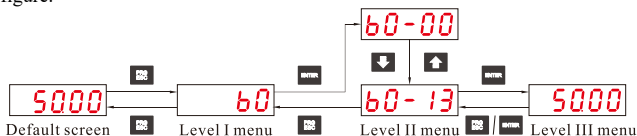

Diagram 4-2 Operation procedure on the operation panel

Instruction: We can return to level II menu from Level III menu by pressing "PRG/ESC" or "ENTER".

The difference between them is:

After you press "ENTER", the system saves the parameter setting first, and then goes back to Level II menu and shifts to the next function code.

After you press "PRG/ESC", the system does not save the parameter setting, but directly returns to Level II menu and remains at the present function code.

Under the Level III state, if there is no blinking digit of this parameter, then it indicates that the parameter can not to be modified. The possible reasons are:

1. This function code is a non-modifiable parameter, such as the actual testing parameters, operation records, etc.
2. This function code cannot be modified under the running state, but can modify after stopping.

4.3 Monitoring Status Parameters

In the stop or running status, you can press " » " on the operation panel to display various status parameters. Whether parameters are displayed is

determined by the binary bits of values converted from the values of b9-02(Displaying parameters on running status 1), b9-03(Displaying parameters on running status 2), and b9-04(Displaying parameters on stop status) in the hexadecimal format.

In stop status, there are 16 status parameters you can select to displayed or not, they are: setting frequency, bus voltage, DI input status, DO output status, analog input AI1 voltage, analog input AI2 voltage, analog input AI3 voltage, count value, length value, PLC running step, load speed, PID setting, PULSE input frequency and three reserved parameters.

In running state, there are five running status parameters: running frequency, setting frequency, bus voltage, output voltage and output current. This five parameters are default displaying. The other display parameters includes output power, output torque, DI input status, DO output status, analog input AI1 voltage, analog input AI2 voltage, analog input AI3 voltage, count value, length value, linear speed, PID setting, PID feedback, etc. You can set whether these parameters are displayed or not by setting b9-02 and b9-03.

When the frequency inverter is repowered on again after power failure, the parameters are recorded as before power failure and displaying.

4.4 Password Setting

The frequency inverter provides the user password protection function. When A0-00 is set to a non-zero value, the value is the user password. The password takes effect after you exit the function code editing status. When you press "PRG" key, the "-----" will be displayed, and you must enter the correct user password to unlock the menu.

To cancel the password protection function, enter with password and set A0-00 to 0.

4.5 Motor parameter auto-tuning

Select vector control running mode, before frequency inverter start to operate, you must accurately write in the nameplate parameter of motor by keypad. EM10 frequency inverter will match standard motor parameter according to the nameplate; the vector control mode strongly depended on motor's parameters, if you want to get good control performance, then you must let inverter to obtain the exact parameters of controlled motor.

The process of motor auto-tuning is as follows:

Firstly, select command source (b0-02) as keypad command channel. Then write in the actual motor parameters as the following parameters (according to the nameplate of present motor):

Parameters
d0-00: Motor Rated Power(kW)
d0-01: Motor Rated Voltage(V)
d0-02: Motor Rated Current(A)
d0-03: Motor Rated Frequency(Hz)
d0-04: Motor Rated Speed(Rpm)

AC asynchronous motor tuning

If the motor can be disconnected from the load, then please set d0-30 to 2(asynchronous motor dynamic complete auto-tuning), If the motor cannot be disconnected with the load, then please select d0-30 to 3 (asynchronous motor static complete auto-tuning), then press the RUN key on the keypad. The frequency inverter will automatically calculate the following parameters of motor:

Parameters
d0-05: Stator resistance (asynchronous motor)
d0-06: Rotor resistance (asynchronous motor)
d0-07: Leakage inductive reactance(asynchronous motor)
d0-08: Mutual inductive reactance(asynchronous motor)
d0-09: No-load current(asynchronous motor)

After finishing motor parameter auto-tuning.

4.6 Function Code Table

If A0-00 is set to a non-zero number, parameter protection is enabled. You must write in correct user password to enter the menu.

To cancel the password protection function, enter with password and set A0-00 to 0.

The parameter menu under the user-defined parameter mode can directly enter without password.

Group “A” is frequency inverter system parameter. Group “b” is basic function parameters. Group “C” is application parameter, Group “d” is control parameter, and Group “U” is monitoring function parameters.

The symbols in the function code table are described as follows:

Standard Function Parameters

Code	Parameter Name	Functional description	Default	Property
Group b0: Basic Function Parameters				
b0-00	Motor type selection	0: AC asynchronous motor	0	★
b0-01	Motor control mode	0: Sensor-less vector control (SVC) 1 or 2: V/F control 3: Closed-loop vector control (FVC)	2	★
b0-02	Command source selection	0: Keypad control (LED off) 1: Terminal control (LED on) 2: Communication control (LED blinking)	0	★
b0-03	Main frequency source X selection	0: Digital setting (Digital setting frequency b0-12, UP/DOWN modifiable, no-record after power off) 1: Digital setting (Digital	1	★

Code	Parameter Name	Functional description	Default	Property
		setting frequency b0-12, UP/DOWN modifiable, record after power off) 2: AI1 3: AI2 4: AI3 5: Pulse setting (HDI) 6: Multi-function 7: Built-in PLC 8: PID 9: Communication setting 10. Keypad Potentiometer(Only for EM10A)		
b0-04	Auxiliary frequency source Y selection	The same as b0-03 (Main frequency source X selection)	0	★
b0-05	Selection of auxiliary frequency Y range	0: Relative to maximum frequency 1: Relative to main frequency X	0	☆
b0-06	Range of auxiliary frequency Y	0%~150%	100%	☆
b0-07	Frequency source logic selection	Unit's digit: Frequency source selection. 0: Only by Main frequency source X(b0-03) 1: X and Y calculation (calculation result determined by ten's digit) 2: Switchover between X and Y	0	☆

Code	Parameter Name	Functional description	Default	Property
		3: Switchover between X and "X and Y calculation" 4: Switchover between Y and "X and Y calculation" Ten's digit: X and Y calculation relationship 0: X+Y 1: X-Y 2: Maximum of them 3: Minimum of them		
b0-08	Encoder knob frequency change unit	0:1Hz 1:0.1Hz 2:0.2Hz	0	☆
b0-09	Binding command source to frequency source	Unit's digit: Binding keypad command to following frequency source. 0: No binding 1: Digital setting frequency 2: AI1 3: AI2 4: AI3 5: Pulse setting (HDI) 6: Multi-function 7: Simple PLC 8: PID 9: Communication setting Ten's digit: Binding terminal command to frequency source. 0~9, same as unit's digit Hundred's digit: Binding communication command to	0	☆

Code	Parameter Name	Functional description	Default	Property
		frequency source. 0~9, same as unit's digit Thousand's digit: Automatically running binding to frequency source. 0~9, same as unit's digit		
b0-10	Record of digital setting frequency at power failure	0: not record 1:record	1	☆
b0-11	Frequency unit	1: 0.1 Hz 2: 0.01 Hz	2	☆
b0-12	Digital setting frequency	0.00 ~ maximum frequency (b0-13)	50.00 Hz	☆
b0-13	Maximum frequency	50.00~3200.00 Hz	50.00 Hz	☆
b0-14	Source of frequency upper limit	0: Set by (b0-15) 1: AI1 2: AI2 3: AI3 4: Pulse setting (HDI) 5: Communication setting	0	☆
b0-15	Frequency upper limit	Frequency lower limit (b0- 17) ~ maximum frequency (b0-13)	50.00 Hz	☆
b0-16	Frequency upper limit offset	0.00 Hz~ maximum frequency(b0-13)	0.00 Hz	☆
b0-17	Frequency lower limit	0.00 Hz ~frequency upper limit(b0-15)	0.00 Hz	☆
b0-18	Rotation direction	0: Forward direction 1: Reverse direction	0	☆
b0-19	Base frequency for UP/ DOWN modification	0: Running frequency 1: Setting frequency	0	★

Code	Parameter Name	Functional description	Default	Property
	during running			
b0-20	Acceleration/Deceleration mode	0: Linear acceleration/ deceleration 1: S-curve acceleration/deceleration A 2: S-curve acceleration/deceleration B	0	☆
b0-21	Acceleration time 1	0.00s~650.00s (b0-25 = 2) 0.0s~6500.0s (b0-25 = 1) 0s~65000s (b0-25 = 0)	Model dependent	☆
b0-22	Deceleration time 1	0.00s~650.00s (b0-25 = 2) 0.0s~6500.0s (b0-25 = 1) 0s~65000s (b0-25 = 0)	Model dependent	☆
b0-23	Time proportion of S-curve start segment	0.0% ~ (100.0% minus b0-24)	30.0%	☆
b0-24	Time proportion of S-curve end segment	0.0% ~ (100.0% minus b0-23)	30.0%	☆
b0-25	Acceleration/Deceleration time unit	0:1s 1: 0.1s 2: 0.01s	1	☆
b0-26	Acceleration/Deceleration time base frequency	0: Maximum frequency (b0-13) 1: Set frequency 2: 100 Hz	0	★
Group b1: Start and Stop Control Parameters				
b1-00	Start mode	0: Direct start 1: Rotational speed tracking restart 2: Pre-excited start (AC asynchronous motor)	0	★
b1-01	Rotational speed tracking	0: From frequency at stop	0	★

Code	Parameter Name	Functional description	Default	Property
	mode	1: From 50Hz 2: From maximum frequency		
b1-02	Rotational speed tracking responding ratio	1~100	20	★
b1-03	Startup frequency	0.00~10.00 Hz	0.00 Hz	☆
b1-04	Startup frequency holding time	0.0s~100.0s	0.0s	★
b1-05	Startup DC braking current/ Pre-excited current	0%~100%	0%	★
b1-06	Startup DC braking time/ Pre-excited time	0.0s~100.0s	0.0s	★
b1-07	Stop mode	0: Decelerate to stop 1: free stop	0	☆
b1-08	DC braking initial frequency of stopping	0.00 Hz ~ maximum frequency	0.00 Hz	☆
b1-09	DC braking waiting time of stopping	0.0s~100.0s	0.0s	★
b1-10	DC braking current of stopping	0%~100%	0%	★
b1-11	DC braking time of stopping	0.0s~100.0s	0.0s	★
Group b2: Auxiliary Function				
b2-00	JOG running frequency	0.00 Hz ~ maximum frequency	2.00 Hz	☆
b2-01	JOG acceleration time	0.0s~6500.0s	Model dependent	☆
b2-02	JOG deceleration time	0.0s~6500.0s		☆
b2-03	Acceleration time 2	0.0s~6500.0s		☆
b2-04	Deceleration time 2	0.0s~6500.0s		☆
b2-05	Acceleration time 3	0.0s~6500.0s		☆
b2-06	Deceleration time 3	0.0s~6500.0s		Model

Code	Parameter Name	Functional description	Default	Property
b2-07	Acceleration time 4	0.0s~6500.0s	dependent	☆
b2-08	Deceleration time 4	0.0s~6500.0s		☆
b2-09	Jump frequency 1	0.00 Hz ~maximum frequency	0.00 Hz	☆
b2-10	Jump frequency 2	0.00 Hz ~ maximum frequency	0.00 Hz	☆
b2-11	Frequency jump amplitude	0.00 Hz ~ maximum frequency	0.00Hz	☆
b2-12	Jump frequency during acceleration/ deceleration	0: Disabled 1: Enabled	0	☆
b2-13	Frequency switchover point between acceleration time 1 and acceleration time 2	0.00 Hz ~ maximum frequency	0.00Hz	☆
b2-14	Frequency switchover point between deceleration time 1 and deceleration time 2	0.00 ~ maximum frequency	0.00Hz	☆
b2-15	Reverse running	0: Enabled 1: Disabled	0	☆
b2-16	Forward/Reverse rotation dead-zone time	0.0~3000.0s	0.0s	☆
b2-17	Running mode when set frequency less than limited lower frequency	0: Run at frequency lower limit 1: Stop 2: Run at zero speed	0	☆
b2-18	Droop control	0.00Hz~10.00 Hz	0.00Hz	☆
b2-19	Terminal JOG priority	0: Disabled 1: Enabled	0	☆
b2-21	Setting running time reach threshold	0~65000 h	0h	☆

Code	Parameter Name	Functional description	Default	Property
b2-22	Action after running time reached	0: Continue to run 1: Stop	0	☆
b2-23	Cooling fan control	0: Fan working during running 1: Fan working during power on	0	☆
b2-24	Dormant frequency	0.00Hz ~wakeup frequency (b2-26)	0.00Hz	☆
b2-25	Dormant delay time	0.0s~6000.0s	0.0s	☆
b2-26	Wakeup frequency	Dormant frequency (b2-24)~maximum frequency (b0-13)	0.00Hz	☆
b2-27	Wakeup delay time	0.0s~6000.0s	0.0s	☆
b2-28	Timing function	0: Disabled 1: Enabled	0	☆
b2-29	Timing duration source	0: b2-30 1: AI1 2: AI2 3: AI3 (100% of analog input corresponds to the value of b2-30)	0	☆
b2-30	Set timing duration	0.0min~6500.0 min	0.0min	☆
b2-31	This time running time reached threshold	0.0min~6500.0 min	0.0min	☆
b2-32	DI terminal status after power on	0: Valid 1: Invalid	0	☆
Group b3: Switch Input Terminal Parameters				
b3-00	DI1 function selection	0: No function 1: Forward RUN (FWD) or running command 2: Reverse RUN (REV) or	01	★
b3-01	DI2 function selection		02	★
b3-02	DI3 function selection		06	★
b3-03	DI4 function selection		07	★

Code	Parameter Name	Functional description	Default	Property
b3-04	DI5 function selection	FWD/REV running direction	38	★
b3-05	reserved control terminal for expansion	3: Three-line control 4: Forward JOG (FJOG) 5: Reverse JOG (RJOG) 6: Multi-function terminal 1 7: Multi-function terminal 2 8: Multi-function terminal 3 9: Multi-function terminal 4 10: Terminal UP 11: Terminal DOWN 12: clear to zero of UP and DOWN setting (terminal, keypad) 13: Terminal 1 for acceleration/ deceleration time selection 14: Terminal 2 for acceleration/ deceleration time selection	00	★
b3-06	HDI function selection	15: Frequency source switchover 16: Switchover between main frequency source X and digital setting frequency 17: Switchover between auxiliary frequency source Y and digital setting frequency 18: Terminal 1 for Command source switchover 19: Terminal 2 for Command source switchover 20: Speed control/Torque	32	★

Code	Parameter Name	Functional description	Default	Property
		control switchover 21: Torque control prohibited 22: PID pause 23: PID integral pause 24: Reverse PID action direction 25: PID parameter switchover 26: PLC status reset 32: Pulse input (enabled only for HDI) 33: Frequency modification enable 34: Acceleration/Deceleration prohibited 36: Motor selection terminal 2(reserve) 37: Fault reset 38: Normally open (NO) input of external fault 39: Normally closed (NC) input of external fault 40: User-defined fault 1 41: User-defined fault 2 42: Running pause 43: Free stop 44: Emergency stop 45: External STOP terminal 1 46: External STOP terminal 2		

Code	Parameter Name	Functional description	Default	Property
		47: Deceleration DC braking 48: Immediate DC braking 49: Clear the current running time		
b3-12	DI filter time	0.000s~1.000s	0.010s	☆
b3-13	Terminal command mode	0: Two-line mode 1 1: Two-line mode 2 2: Three-line mode 1 3: Three-line mode 2	0	★
b3-14	Rate of UP/DOWN terminal	0.001Hz/s~65.535 Hz/s	1.000 Hz/s	☆
b3-15	DI1 ON delay time	0.0s~3000.0s	0.0s	☆
b3-16	DI1 OFF delay time	0.0s~3000.0s	0.0s	☆
b3-17	DI2 ON delay time	0.0s~3000.0s	0.0s	☆
b3-18	DI2 OFF delay time	0.0s~3000.0s	0.0s	☆
b3-19	DI3 ON delay time	0.0s~3000.0s	0.0s	☆
b3-20	DI3 OFF delay time	0.0s~3000.0s	0.0s	☆
b3-21	DI4 ON delay time	0.0s~3000.0s	0.0s	☆
b3-22	DI4 OFF delay time	0.0s~3000.0s	0.0s	☆
b3-23	DI5 ON delay time	0.0s~3000.0s	0.0s	☆
b3-24	DI5 OFF delay time	0.0s~3000.0s	0.0s	☆
b3-25	DI valid selection 1	Unit's digit: DI1 valid mode. 0: High level valid 1: Low level valid Ten's digit: DI2 valid mode: 0, 1 (same as DI1) Hundred's digit: DI3 valid mode: 0, 1 (same as DI1) Thousand's digit: DI4 valid mode: 0, 1 (same as DI1) Ten thousand's digit: DI5	00000	★

Code	Parameter Name	Functional description	Default	Property
		valid mode: 0, 1 (same as DI1)		
Group b4: Switch Signal output Terminals				
b4-00	FM terminal output mode	0: Pulse output 1: Open- collector output terminal	0	☆
b4-01	FMR function (open-collector output terminal)	0: No output 1: Ready signal	0	☆
b4-02	Relay 1 function (TA1-TB1-TC1)	2: Frequency inverter running	3	☆
b4-03	Relay 2 function (TA2-TB2-TC2)	3: Fault output (free stop fault) 4: Fault output (free stop fault, but do not output when lower voltage) 5: Swing frequency limit 6: Torque limit 7: Frequency upper limit reached 8: Frequency lower limit reached (relevant to running) 9: Frequency lower limit reached (having output at stop) 10: Reverse running 11: Zero-speed running (no output at stop) 12: Zero-speed running 2 (having output at stop) 16: PLC cycle complete 17: Frequency-level detection FDT1 output	2	☆

Code	Parameter Name	Functional description	Default	Property
		18: Frequency level detection FDT2 output 19: Frequency reached 20: Frequency 1 reached 21: Frequency 2 reached 22: Current 1 reached 23: Current 2 reached 24: Module temperature reached 25: Timing reached 26: Zero current state 27: Output current exceeded limitation 28: Lower voltage state output 29: Frequency inverter overload pre-warning 30: Motor overheat pre- warning 31: Motor overload pre- warning 32: off load 33: AI1 larger than AI2 34: AI1 input exceeded limitation 35: Alarm output (all faults) 36: Present running time reached 37: Accumulative power-on time reached 38: Accumulative running time reached		

Code	Parameter Name	Functional description	Default	Property
		39: Communication setting		
b4-10	FMR ON delay time	0.0s~3000.0s	0.0s	☆
b4-11	FMR OFF delay time	0.0s~3000.0s	0.0s	☆
b4-12	Relay 1 ON delay time	0.0s~3000.0s	0.0s	☆
b4-13	Relay 1 OFF delay time	0.0s~3000.0s	0.0s	☆
b4-14	Relay 2 ON delay time	0.0s~3000.0s	0.0s	☆
b4-15	Relay 2 OFF delay time	0.0s~3000.0s	0.0s	☆
b4-20	DO logic selection 1	Unit's digit: FMR valid mode. 0: Positive logic 1: Negative logic Ten's digit: Relay 1 valid mode: 0, 1 (same as FMR) Hundred's digit: Relay 2 valid mode: 0, 1 (same as FMR) Thousand's digit: DO1 valid model 0, 1 (same as FMR) Ten thousand's digit: DO2 valid mode: 0, 1 (same as FMR)	00000	☆
b4-22	Frequency detection value 1 (FDT1)	0.00 Hz~ maximum frequency	50.00 Hz	☆
b4-23	Frequency detection hysteresis 1 (FDT hysteresis 1)	0.0%~100.0% (FDT1 level)	5.0%	☆
b4-24	Detection width of frequency	0.00% ~ 100%(maximum frequency)	0.0%	☆
b4-25	Frequency detection value 2 (FDT2)	0.00 Hz ~ maximum frequency	50.00HZ	☆
b4-26	Frequency detection	0.00~100% (maximum	5.0%	☆

Code	Parameter Name	Functional description	Default	Property
	hysteresis 2 (FDT hysteresis 2)	frequency)		
b4-27	Any frequency reaching detection value 1	0.00 Hz ~ maximum frequency	50.00 Hz	☆
b4-28	Any frequency reaching detection amplitude 1	0.0%~100.0% (maximum frequency)	0.0%	☆
b4-29	Any frequency reaching detection value 2	0.00 Hz ~ maximum frequency	50.00 Hz	☆
b4-30	Any frequency reaching detection amplitude 2	0.0%~100.0% (maximum frequency)	0.0%	☆
b4-31	Zero current detection level	0.0%~100.0% (rated motor current)	5.0%	☆
b4-32	Zero current detection delay time	0.00s~600.00s	0.10s	☆
b4-33	Over current output threshold	0.0%~300.0% (rated motor current)	200.0%	☆
b4-34	Over current output detection delay time	0.00s~600.00s	0.00s	☆
b4-35	Any current reaching 1	0.0%~100.0% (rated motor current)	100.0%	☆
b4-36	amplitude of any current reaching 1	0.0%~100.0% (rated motor current)	0.0%	☆
b4-37	Any current reaching 2	0.0%~100.0% (rated motor current)	100.0%	☆
b4-38	Amplitude of any current reaching 2	0.0%~100.0% (rated motor current)	0.0%	☆
b4-39	IGBT module temperature threshold	25~100°C	75°C	☆
Group b5: Pulse/Analog input terminals				
b5-00	Pulse minimum input(HDI)	0.00 kHz ~b5-02	0.00 kHz	☆

Code	Parameter Name	Functional description	Default	Property
b5-01	Corresponding setting of pulse minimum input	-100.00% ~100.0%	0.00%	☆
b5-02	Pulse maximum input	b5-00 ~ 100.00 kHz	50.00 kHz	☆
b5-03	Corresponding setting of pulse maximum input	-100.00% ~100.0%	100.0%	☆
b5-04	Pulse filter time	0.00s~10.00s	0.10s	☆
b5-05	All input voltage lower limit of protection	0.00 V~ b5-06	3.10 V	☆
b5-06	All input voltage upper limit of protection	b5-05~10.00 V	6.80 V	☆
b5-07	All input minimum value	0.00 V ~ b5-09	0.00V	☆
b5-08	Corresponding setting of All minimum input	-100.00% ~100.0%	0.0%	☆
b5-09	All Maximum input value	0.00V~10.00V	10.00V	☆
b5-10	Corresponding setting of All Maximum input value	-100.0%~100.0%	100.0%	☆
b5-11	All input filter time	0.00s~10.00s	0.10s	☆
b5-12	All input minimum value	0.00V~10.00V	2.00V	☆
b5-13	Corresponding setting of All minimum input	-100.0%~100.0%	0.0%	☆
b5-14	All Maximum input value	0.00V~10.00V	10.00V	☆
b5-15	Corresponding setting of All Maximum input value	-100.0%~100.0%	100.0%	☆
b5-16	All input filter time	0.00s~10.00s	0.10s	☆
b5-17	All input minimum value	-10.00V~10.00V	-10.00V	☆
b5-18	Corresponding setting of All minimum input	-100.0%~100.0%	-100.0%	☆

Code	Parameter Name	Functional description	Default	Property
b5-19	AI3 Maximum input value	-10.00V~10.00V	10.00V	☆
b5-20	Corresponding setting of AI3 Maximum input value	-100.0%~100.0%	100.0%	☆
b5-21	AI3 input filter time	0.00s~10.00s	0.10s	☆
b5-22	AI curve 4 minimum input	-10.00V~b5-24	0.00V	☆
b5-23	Corresponding setting of AI curve 4 minimum input	-100.0%~+100.0%	0.0%	☆
b5-24	AI curve 4 inflection point 1 input	B5-21~b5-26	3.00V	☆
b5-25	Corresponding setting of AI curve 4 inflection point 1 input	-100.0%~+100.0%	30.0%	☆
b5-26	AI curve 4 inflection point 2 input	b5-23~b5-27	6.00V	☆
b5-27	Corresponding setting of AI curve 4 inflection point 2 input	-100.0%~+100.0%	60.0%	☆
b5-28	AI curve 4 Maximum input	b5-27~+10.00V	10.00V	☆
b5-29	Corresponding setting of AI curve 4 Maximum input	-100.0%~+100.0%	100.0%	☆
b5-30	AI curve 5 minimum input	-10.00V~b5-31	-10.00V	☆
b5-31	Corresponding setting of AI curve 5 minimum input	-100.0%~+100.0%	-100.0%	☆

Code	Parameter Name	Functional description	Default	Property
b5-32	AI curve 5 inflection point 1 input	b5-28~b5-33	-3.00V	☆
b5-33	Corresponding setting of AI curve 5 inflection point 1 input	-100.0%~+100.0%	-30.0%	☆
b5-34	AI curve 5 inflection point 2 input	b5-31~b5-35	3.00V	☆
b5-35	Corresponding setting of AI curve 5 inflection point 2 input	-100.0%~+100.0%	30.0%	☆
b5-36	AI curve 5 Maximum input	b5-33~+10.00V	10.00V	☆
b5-37	Corresponding setting of AI curve 5 Maximum input	-100.0%~+100.0%	100.0%	☆
b5-38	AI1 jump point	-100.0%~100.0%	0.0%	☆
b5-39	AI1 jump amplitude	0%~100.0%	0.5%	☆
b5-40	AI2 jump point	-100.0%~100.0%	0.0%	☆
b5-41	AI2 jump amplitude	0%~100.0%	0.5%	☆
b5-42	AI3 jump point	-100.0%~100.0%	0.0%	☆
b5-43	AI3 jump amplitude	0%~100.0%	0.5%	☆
b5-44	AI curve selection	Unit's digit: AI1 curve selection 1: curve 1(2 point, refer b5-07~b5-10) 2: curve 2(2 point, refer b5-12~b5-15) 3: curve 3(2 point, refer b5-17~b5-20) 4: curve 4(4 point, refer b5-22~b5-29)	H321	☆

Code	Parameter Name	Functional description	Default	Property
		5: curve 5(4 point, refer b5-30~b5-37) Ten's digit:AI2curve selection, same as above Hundred's digit:AI3 curve selection, same as above		
b5-45	AI lower than minimum input setting selection	Unit's digit:AI1 lower than minimum input setting 0: Corresponding minimum input setting 1:0.0% Ten's digit:AI2 lower than minimum input setting selection, same as above Hundred's digit:AI3 lower than minimum input setting selection, same as above	H.000	☆
Group b6: Pulse/Analog Output Terminals				
b6-00	FMP function selection	0: Running frequency corresponding to 0~Max. operation frequency 1: Set frequency corresponding to 0~Max. operation frequency 2: Output current corresponding to 0~Doubled motor rated current 3: Output torque (absolute value) corresponding to 0~double rated torque 4: Output power corresponding to 0~Doubled	0	☆
b6-01	AO1 output function selection		0	☆
b6-02	AO2 output function selection		1	☆

Code	Parameter Name	Functional description	Default	Property
		motor rated power 5: Output voltage corresponding to 0~1.2 times DC bus voltage 6: Pulse input corresponding to 0Hz~100kHz 7: AI1 corresponding to 0~10V 8: AI2 corresponding to 0~10V 9: AI3 corresponding to 0~10V 12: Communication setting corresponding to 0~32767 13: Motor rotational speed corresponding to 0~Max. operation frequency 14: Output current corresponding to 0~1000A 15: Output voltage corresponding to 0~1000V 16: Output torque corresponding to (- 200%~200%) motor rated torque		
b6-03	Maximum FMP output frequency	0.01 kHz ~100.00 kHz	50.00 kHz	☆
b6-04	AO1 offset coefficient	-100.0% ~100.0%	0.0%	☆
b6-05	AO1 gain	-10.00~10.00	1.00	☆
b6-06	AO2 offset coefficient	-100.0% ~100.0%	0.00%	☆
b6-07	AO2 gain	-10.00 ~10.00	1.00	☆

Code	Parameter Name	Functional description	Default	Property
Group b7 : Virtual DI (VDI)/Virtual DO (VDO)				
b7-00	VDI1 function selection	0~49	0	★
b7-01	VDI2 function selection	0~49	0	★
b7-02	VDI3 function selection	0~49	0	★
b7-03	VDI4 function selection	0~49	0	★
b7-04	VDI5 function selection	0~49	0	★
b7-05	VDI state setting mode	Unit's digit: VDI1. 0: Valid decided by state of VDOx 1: Valid decided by b7-06 Ten's digit: VDI2: 0, 1 (same as VDI1) Hundred's digit: VDI3: 0, 1 (same as VDI1) Thousand's digit: VDI4: 0, 1 (same as VDI1) Ten thousand's digit: VDI5: 0, 1 (same as VDI1)	00000	☆
b7-06	VDI state setting	Unit's digit: VDI1. 0: Invalid 1: Valid Ten's digit: VDI2: 0, 1 (same as VDI1) Hundred's digit: VDI3: 0, 1 (same as VDI1) Thousand's digit: VDI4: 0, 1 (same as VDI1) Ten thousand's digit: VDI5: 0, 1 (same as VDI1)	00000	☆
b7-07	Function selection for All used as DI	0~49	0	★

Code	Parameter Name	Functional description	Default	Property
b7-08	Function selection for AI2 used as DI	0~49	0	★
b7-09	Function selection for AI3 used as DI	0~49	0	★
b7-10	Valid state selection for AI used as DI	Unit's digit: AI1. 0: High level valid 1: Low level valid Ten's digit: AI2: 0, 1 (same as unit's digit) Hundred's digit: AI3: 0, 1 (same as unit's digit)	0	☆
b7-11	VDO1 function selection	0: connect with physical DIx internally 1~40	0	☆
b7-12	VDO2 function selection		0	☆
b7-13	VDO3 function selection		0	☆
b7-14	VDO4 function selection		0	☆
b7-15	VDO5 function selection		0	☆
b7-16	VDO1 output delay	0.0s~3000.0s	0.0s	☆
b7-17	VDO2 output delay	0.0s~3000.0s	0.0s	☆
b7-18	VDO3 output delay	0.0s~3000.0s	0.0s	☆
b7-19	VDO4 output delay	0.0s~3000.0s	0.0s	☆
b7-20	VDO5 output delay	0.0s~3000.0s	0.0s	☆
b7-21	VDO valid state selection	Unit's digit: VDO1. 0: Positive logic valid 1: Reverse logic valid Ten's digit: VDO2: 0, 1 (same as unit's digit) Hundred's digit: VDO3: 0, 1 (same as unit's digit) Thousand's digit: VDO4: 0, 1 (same as unit's digit) Ten thousand's digit: VDO5:	00000	☆

Code	Parameter Name	Functional description	Default	Property
		0, 1 (same as unit's digit)		
Group b9: Keypad and Display				
b9-00	STOP/RESET key function	0: STOP/RESET key enabled only in operation panel control 1: STOP/RESET key enabled in any operation mode	1	☆
b9-01	MF.K Key function selection	0: MF.K key disabled 1: Switchover between operation panel control and remote command control (terminal or communication) 2: Switchover between forward rotation and reverse rotation 3: Forward JOG 4: Reverse JOG 5. Function parameters	3	☆
b9-02	LED display running parameters 1	0000~FFFF Bit00: Running frequency 1 (Hz) Bit01: Setting frequency (Hz) Bit02: DC bus voltage (V) Bit03: Output voltage (V) Bit04: Output current (A) Bit05: Output power (kW) Bit06: Output torque (%) Bit07: DI input status Bit08: DO output status Bit09: AI1 voltage (V)	H.001F	☆

Code	Parameter Name	Functional description	Default	Property
		Bit10: AI2 voltage (V) Bit11: AI3 voltage (V) Bit12: Count value Bit13: Length value Bit14: Load speed display Bit15: PID setting		
b9-03	LED display running parameters 2	0000~FFFF Bit00: PID feedback Bit01: PLC stage Bit02: Pulse setting frequency (kHz) Bit03: Running frequency 2 (Hz) Bit04: Remaining running time Bit05: AI1 voltage before calibration (V) Bit06: AI2 voltage before calibration (V) Bit07: AI3 voltage before calibration (V) Bit08: Linear speed Bit09: Reserved Bit10: Present running time (Min) Bit11: Heat sink temperature display (°C) Bit12: Communication setting value Bit13: Encoder feedback frequency (Hz) Bit14: Main frequency X	H.0000	☆

Code	Parameter Name	Functional description	Default	Property
		display (Hz) Bit15: Auxiliary frequency Y display (Hz)		
b9-04	LED display parameter of stopping	0000~FFFF Bit00: Setting frequency (Hz) Bit01: DC bus voltage (V) Bit02: DI input status Bit03: DO output status Bit04: AI1 voltage (V) Bit05: AI2 voltage (V) Bit06: AI3 voltage (V) Bit07: Count value Bit08: Length value Bit09: PLC stage Bit10: Load speed Bit11: PID setting Bit12: Pulse setting frequency(kHz) Bit13:Heatsink temperature display(°C)	H.0033	☆
b9-05	Load speed display coefficient	0.0001~ 6.5000	0.2920	☆
b9-06	Number of decimal places for load speed display	0: 0 decimal display 1: 1 decimal display 2: 2 decimal display 3: 3 decimal display	0	☆
b9-07	Heatsink temperature	0.0°C ~100.0°C	--	●
b9-08	Accumulative running time	0~65535 h	--	●
b9-09	Accumulative power-on	0~65535 h	--	●

Code	Parameter Name	Functional description	Default	Property
	time			
b9-11	Auxiliary LED display parameters	Corresponding U0 group parameters	00004	●
Group bA: Communication Parameters				
bA-00	Communication type selection	0: Modbus protocol	0	☆
bA-01	Baud ratio setting	Unit's digit: Modbus baud ratio. 0: 300 BPS 1: 600 BPS 2: 1200 BPS 3: 2400 BPS 4: 4800 BPS 5: 9600 BPS 6: 19200 BPS 7: 38400 BPS	5	☆
bA-02	Modbus Data format	0: No check, data format <8,N,2> 1: Even parity check, data format<8,E,1> 2: Odd Parity check, data format<8,O,1> 3: No check, data format <8,N,1> Valid for Modbus	0	☆
bA-03	Broadcast address	0~247 (0: Broadcast address) Valid for Modbus	1	☆
bA-04	Modbus response delay	0~20 ms Only valid for Modbus	2 ms	☆
bA-05	Communication timeout	0.0s:invalid	0.0s	☆

Code	Parameter Name	Functional description	Default	Property
		0.1s~60.0s Valid for Modbus		
bA-06	Modbus protocol data transmission format selection	Unit's digit: Modbus protocol. 0: Non-standard Modbus protocol 1: Standard Modbus protocol Ten's digit: Reserved	31	☆
bA-07	Communication reading current resolution	0: 0.01A 1: 0.1A	0	☆
Group bb: Fault and Protection Setting				
bb-00	G/P type selection	0: P type 1: G type	1	☆
bb-01	Motor overload protection selection	0: Disabled 1: Enabled	1	☆
bb-02	Motor overload protection gain	0.20~10.00	1.00	☆
bb-03	Motor overload pre-warning coefficient	50%~100%	80%	☆
bb-09	Fault auto reset times	0~20(Unlimited number of times)	0	☆
bb-10	Relay action selection during fault auto reset	0: Not act 1: Act	0	☆
bb-11	Time interval of fault auto reset	0.1s~100.0s	1.0s	☆
bb-12	Input phase loss protection/contactor energizing protection selection	Unit's digit: Input phase loss protection 0: Disabled 1: Enabled Ten's digit: Contactor energizing protection	11	☆

Code	Parameter Name	Functional description	Default	Property
		0,1(same as Unit's digit)		
bb-13	Output phase loss protection	0: Disabled 1: Enabled	1	☆
bb-14	Off load protection	0: Disabled 1: Enabled	0	☆
bb-15	Off load detection level	0.0%~100.0% (rated motor current)	10.0%	☆
bb-16	Off load detection time	0.0s~60.0s	1.0s	☆
bb-17	Over-speed detection value	0.0%~50.0% (maximum frequency)	20.0%	☆
bb-18	Over-speed detection time	0.0s~60.0s	1.0s	☆
bb-19	Detection value of too large speed deviation	0.0%~50.0% (maximum frequency)	20.0%	☆
bb-20	Detection time of too large speed deviation	0.0s~60.0s	5.0s	☆
bb-21	Action selection at instantaneous power failure	0: Invalid 1: Decelerate 2: Decelerate to stop	0	☆
bb-22	Judging voltage of instantaneous power failure restoring	60.0%~100.0%(standard bus voltage)	85.0%	☆
bb-23	judging time of Instantaneous power rise	0.00s ~ 100.00s	0.50s	☆
bb-24	Judging voltage of instantaneous power failure	60.0%~100.0% (standard bus voltage)	80.0%	☆
bb-25	Type of motor temperature sensor	0: No temperature sensor 1: PT100 2: PT1000	0	☆
bb-26	Motor overheat protection	0°C~200°C	110°C	☆

Code	Parameter Name	Functional description	Default	Property
	threshold			
bb-27	Motor overheat pre-warning threshold	0°C~200°C	90°C	☆
bb-28	Overvoltage threshold	200.0~2500.0 V	Model	☆
bb-29	Under voltage threshold	200.0V~2000.0V	dependent	☆
bb-30	Brake unit use ratio	0%~100%	100%	☆
bb-32	Fault protection action selection 1	Unit's digit: Motor overload, Err11. 0: Free stop 1: Stop according to the stop mode 2: Continue to run Ten's digit: Power input phase loss, Err12: Same as unit's digit Hundred's digit: Power output phase loss, Err13: Same as unit's digit Thousand's digit: External equipment fault, Err15: Same as unit's digit Ten thousand's digit: Communication fault, Err16: Same as unit's digit	00000	☆
bb-33	Fault protection action selection 2	Unit's digit: Encoder/PG card fault, Err20. 0: Free stop Ten's digit: EEPROM read-write fault, Err21. 0: Free stop 1: Stop according to the stop	00000	☆

Code	Parameter Name	Functional description	Default	Property
		mode Hundred's digit : Reserved Thousand's digit: Motor Overheat, Err25: Same as unit's digit in bb-32 Ten thousand's digit: Running time reached, Err26: Same as unit's digit in bb-32		
bb-34	Fault protection action selection 3	Unit's digit: User-defined fault 1,Err27: Same as unit's digit in bb-32 Ten's digit: User-defined fault 2,Err28: Same as unit's digit in bb-32 Hundred's digit: Accumulative power-on time reached,Err29: Same as unit's digit in bb-32 Thousand's digit: Off load, Err30. 0: Free stop 1: Stop according to the stop mode 2: reduce to 7% of rated motor frequency and continue running. If the load recovers and it will auto regain to setting frequency. Ten thousand's digit: PID feedback lost during running, Err31: Same as unit's digit in bb-32	00000	☆

Code	Parameter Name	Functional description	Default	Property
bb-35	Fault protection action selection 4	Unit's digit: Speed deviation too large, Err42 Same as unit's digit in bb-32 Ten's digit: Motor over-speed, Err43. Same as unit's digit in bb-32 Hundred's digit: Initial position fault, Err51. Same as unit's digit in bb-32	00000	☆
bb-37	Frequency selection for continuing to run of fault	0: Current running frequency 1: Set frequency 2: Frequency upper limit 3: Frequency lower limit 4: Backup frequency of abnormality (bb-37)	0	☆
bb-38	Backup frequency of abnormality	0.0%~100.0% (maximum frequency)	100.0%	☆
bb-39	Inverter overload protection gain	85%-115%	100%	
Group bC: Fault diagnosis				
bC-00	First fault type	—	—	●
bC-01	Second fault type	—	—	●
bC-02	Third fault type (latest)	—	—	●
bC-03	Frequency of latest fault	—	—	●
bC-04	Current of latest fault	—	—	●
bC-05	DC Bus voltage of latest fault	—	—	●
bC-06	Input terminals status of latest fault	—	—	●
bC-07	Output terminal status of latest fault	—	—	●

Code	Parameter Name	Functional description	Default	Property
bC-08	Frequency inverter status of latest fault	—	—	●
bC-09	Power-on time of latest fault	—	—	●
bC-10	Running time of latest fault	—	—	●
bC-11	Frequency of 2nd fault	—	—	●
bC-12	Current of 2nd fault	—	—	●
bC-13	DC Bus voltage of 2nd fault	—	—	●
bC-14	Input terminal status of 2nd fault	—	—	●
bC-15	Output terminal status of 2nd fault	—	—	●
bC-16	Frequency inverter status of 2nd fault	—	—	●
bC-17	Power-on time of 2nd fault	—	—	●
bC-18	Running time of 2nd fault	—	—	●
bC-19	Frequency of 1st fault	—	—	●
bC-20	Current of 1st fault	—	—	●
bC-21	DC Bus voltage of 1st fault	—	—	●
bC-22	Input terminal status of 1st fault	—	—	●
bC-23	Output terminal status of 1st fault	—	—	●
bC-24	Frequency inverter status of 1st fault	—	—	
bC-25	Power-on time of 1st fault	—	—	●
bC-26	Running time of 1st fault	—	—	●

Code	Parameter Name	Functional description	Default	Property
Group bd: Motor protection				
bd-00	Overset alarm current value	0.0~600A	0.00	☆
bd-01	Overcurrent alarm delay time	0.0~600s	0.00	☆
Group C0: PID Control Function				
C0-00	PID setting source	0: C0-01 1: AI1 2: AI2 3: AI3 4: Pulse setting (HDI) 5: Communication setting 6: Multi-function 7: New Mode(Pressure value)	7	☆
C0-01	PID digital setting	0.0%~100.0%	50.0%	☆
C0-02	PID setting change time	0.00s~650.00s	0.00s	☆
C0-03	PID feedback source	0: AI1 1: AI2 2: AI3 3: AI1 – AI2 4: Pulse setting (HDI) 5: Communication setting 6: AI1 + AI2 7: MAX (AI1 , AI2) 8: MIN (AI1 , AI2)	0	☆
C0-04	PID action direction	0: Forward action 1: Reverse action	0	☆
C0-05	PID setting feedback range	0~65535	1000	☆
C0-06	Proportional gain KP1	0.00~100.0	20.0	☆

Code	Parameter Name	Functional description	Default	Property
C0-07	Integral time TI1	0.01s~10.00s	0.80s	☆
C0-08	Differential time TD1	0.000s~10.000s	0.000s	☆
C0-09	Proportional gain KP2	0.00~100.00	20.0	☆
C0-10	Integral time TI2	0.01s~10.00s	2.00s	☆
C0-11	Differential time TD2	0.00s~10.00s	0.000s	☆
C0-12	PID parameter switchover condition	0: No switchover 1: Switchover via DI 2: Automatic switchover based on deviation	0	☆
C0-13	PID parameter switchover deviation 1	0.0% ~ C0-14	20.0%	☆
C0-14	PID parameter switchover deviation 2	C0-13 ~ 100.0%	80.0%	☆
C0-15	PID integral property	Unit's digit: Integral separated. 0: Invalid 1: Valid Ten's digit: Whether to stop integral operation when the output reaches the limit. 0: Continue integral operation 1: Stop integral operation	00	☆
C0-16	PID initial value	0.0%~100.0%	0.0%	☆
C0-17	PID initial value holding time	0.00s~650.00s	0.00s	☆
C0-18	Frequency upper limit of PID reverse rotation	0.00 ~ maximum frequency	0.00 Hz	☆
C0-19	PID deviation limit	0.0%~100.0%	0.0%	☆
C0-20	PID differential limit	0.00%~100.00%	0.10%	☆
C0-21	Maximum positive	0.00%~100.00%	1.00%	☆

Code	Parameter Name	Functional description	Default	Property
	deviation between two PID outputs			
C0-22	Maximum negative deviation between two PID outputs	0.00%~100.00%	1.00%	☆
C0-23	PID feedback filter time	0.00s~60.00s	0.00s	☆
C0-24	PID output filter time	0.00s~60.00s	0.00s	☆
C0-25	Detection value of PID feedback loss	0.0%: Not judging feedback loss 0.1%~100.0%	0.0%	☆
C0-26	Detection time of PID feedback loss	0.0s~20.0s	0.0s	☆
C0-27	PID operation at stop	0: No PID operation at stop 1: PID operation at stop	1	☆
Group C1: Multi-function				
C1-00	Multi-function 0	-100.0%~100.0%	0.0%	☆
C1-01	Multi-function 1	-100.0%~100.0%	0.0%	☆
C1-02	Multi-function 2	-100.0%~100.0%	0.0%	☆
C1-03	Multi-function 3	-100.0%~100.0%	0.0%	☆
C1-04	Multi-function 4	-100.0%~100.0%	0.0%	☆
C1-05	Multi-function 5	-100.0%~100.0%	0.0%	☆
C1-06	Multi-function 6	-100.0%~100.0%	0.0%	☆
C1-07	Multi-function 7	-100.0%~100.0%	0.0%	☆
C1-08	Multi-function 8	-100.0%~100.0%	0.0%	☆
C1-09	Multi-function 9	-100.0%~100.0%	0.0%	☆
C1-10	Multi-function 10	-100.0%~100.0%	0.0%	☆
C1-11	Multi-function 11	-100.0%~100.0%	0.0%	☆
C1-12	Multi-function 12	-100.0%~100.0%	0.0%	☆
C1-13	Multi-function 13	-100.0%~100.0%	0.0%	☆
C1-14	Multi-function 14	-100.0%~100.0%	0.0%	☆
C1-15	Multi-function 15	-100.0%~100.0%	0.0%	☆

Code	Parameter Name	Functional description	Default	Property
C1-16	Multi-function 0 source	0: Set by C1-00 1: AI1 2: AI2 3: AI3 4: Pulse setting(HDI) 5: PID 6: Set by digital setting frequency (b0-12), modified via terminal UP/ DOWN	0	☆
Group C2: Simple PLC				
C2-00	Simple PLC running mode	0: Stop after the Frequency inverter runs one cycle 1: Keep final values after the frequency inverter runs one cycle 2: Repeat after the frequency inverter runs one cycle	0	☆
C2-01	Simple PLC record selection	Unit's digit: Record of power failure. 0: No record after power off 1: Record after power off Ten's digit: Record of stopping. 0: No record after stopping 1: Record after stopping	00	☆
C2-02	Running time of simple PLC Segment 0	0.0s(h)~6553.5s(h)	0.0s (h)	☆
C2-03	Acceleration/deceleration time of simple PLC Segment 0	0~3	0	☆
C2-04	Running time of simple	0.0s(h)~6553.5s(h)	0.0s (h)	☆

Code	Parameter Name	Functional description	Default	Property
	PLC Segment 1			
C2-05	Acceleration/deceleration time of simple PLC Segment 1	0~3	0	☆
C2-06	Running time of simple PLC Segment 2	0.0s(h)~6553.5s(h)	0.0s (h)	☆
C2-07	Acceleration/deceleration time of simple PLC Segment 2	0~3	0	☆
C2-08	Running time of simple PLC Segment 3	0.0s(h)~6553.5s(h)	0.0s (h)	☆
C2-09	Acceleration/deceleration time of simple PLC Segment 3	0~3	0	☆
C2-10	Running time of simple PLC Segment 4	0.0s(h)~6553.5s(h)	0.0s (h)	☆
C2-11	Acceleration/deceleration time of simple PLC Segment 4	0~3	0	☆
C2-12	Running time of simple PLC Segment 5	0.0s(h)~6553.5s(h)	0.0s (h)	☆
C2-13	Acceleration/deceleration time of simple PLC Segment 5	0~3	0	☆
C2-14	Running time of simple PLC Segment 6	0.0s(h)~6553.5s(h)	0.0s (h)	☆
C2-15	Acceleration/deceleration time of simple PLC Segment 6	0~3	0	☆
C2-16	Running time of simple PLC Segment 7	0.0s(h)~6553.5s(h)	0.0s (h)	☆

Code	Parameter Name	Functional description	Default	Property
C2-17	Acceleration/deceleration time of simple PLC Segment 7	0~3	0	☆
C2-18	Running time of simple PLC Segment 8	0.0s(h)~6553.5s(h)	0.0s (h)	☆
C2-19	Acceleration/deceleration time of simple PLC Segment 8	0~3	0	☆
C2-20	Running time of simple PLC Segment 9	0.0s(h)~6553.5s(h)	0.0s (h)	☆
C2-21	Acceleration/deceleration time of simple PLC Segment 9	0~3	0	☆
C2-22	Running time of simple PLC Segment 10	0.0s(h)~6553.5s(h)	0.0s (h)	☆
C2-23	Acceleration/deceleration time of simple PLC Segment 10	0~3	0	☆
C2-24	Running time of simple PLC Segment 11	0.0s(h)~6553.5s(h)	0.0s (h)	☆
C2-25	Acceleration/deceleration time of simple PLC Segment 11	0~3	0	☆
C2-26	Running time of simple PLC Segment 12	0.0s(h)~6553.5s(h)	0.0s (h)	☆
C2-27	Acceleration/deceleration time of simple PLC Segment 12	0~3	0	☆
C2-28	Running time of simple PLC Segment 13	0.0s(h)~6553.5s(h)	0.0s (h)	☆
C2-29	Acceleration/deceleration	0~3	0	☆

Code	Parameter Name	Functional description	Default	Property
	time of simple PLC Segment 13			
C2-30	Running time of simple PLC Segment 14	0.0s(h)~6553.5s(h)	0.0s (h)	☆
C2-31	Acceleration/deceleration time of simple PLC Segment 14	0~3	0	☆
C2-32	Running time of simple PLC Segment 15	0.0s(h)~6553.5s(h)	0.0s (h)	☆
C2-33	Acceleration/deceleration time of simple PLC Segment 15	0~3	0	☆
C2-34	Time unit of simple PLC running	0: s (second) 1: h (hour)	0	☆
C2-35	PLC function selection	0:C2-02~C2-34 is valid 1:C2-35~C2-68 is valid	0	☆
C2-36	Acceleration time of Segment 0	0.0S-3000.0S	10.0s	☆
C2-37	deceleration time of Segment 0	0.0S-3000.0S	10.0s	☆
C2-38	Acceleration time of Segment 1	0.0S-3000.0S	10.0s	☆
C2-39	deceleration time of Segment 1	0.0S-3000.0S	10.0s	☆
C2-40	Acceleration time of Segment 2	0.0S-3000.0S	10.0s	☆
C2-41	deceleration time of Segment 2	0.0S-3000.0S	10.0s	☆
C2-42	Acceleration time of Segment 3	0.0S-3000.0S	10.0s	☆
C2-43	deceleration time of	0.0S-3000.0S	10.0s	☆

Code	Parameter Name	Functional description	Default	Property
	Segment 3			
C2-44	Acceleration time of Segment 4	0.0S-3000.0S	10.0s	☆
C2-45	deceleration time of Segment 4	0.0S-3000.0S	10.0s	☆
C2-46	Acceleration time of Segment 5	0.0S-3000.0S	10.0s	☆
C2-47	deceleration time of Segment 5	0.0S-3000.0S	10.0s	☆
C2-48	Acceleration time of Segment 6	0.0S-3000.0S	10.0s	☆
C2-49	deceleration time of Segment 6	0.0S-3000.0S	10.0s	☆
C2-50	Acceleration time of Segment 7	0.0S-3000.0S	10.0s	☆
C2-51	deceleration time of Segment 7	0.0S-3000.0S	10.0s	☆
C2-52	Acceleration time of Segment 8	0.0S-3000.0S	10.0s	☆
C2-53	deceleration time of Segment 8	0.0S-3000.0S	10.0s	☆
C2-54	Acceleration time of Segment 9	0.0S-3000.0S	10.0s	☆
C2-55	deceleration time of Segment 9	0.0S-3000.0S	10.0s	☆
C2-56	Acceleration time of Segment 10	0.0S-3000.0S	10.0s	☆
C2-57	deceleration time of Segment 10	0.0S-3000.0S	10.0s	☆
C2-58	Acceleration time of Segment 11	0.0S-3000.0S	10.0s	☆

Code	Parameter Name	Functional description	Default	Property
C2-59	deceleration time of Segment 11	0.0S-3000.0S	10.0s	☆
C2-60	Acceleration time of Segment 12	0.0S-3000.0S	10.0s	☆
C2-61	Acceleration time of Segment 12	0.0S-3000.0S	10.0s	☆
C2-62	deceleration time of Segment 13	0.0S-3000.0S	10.0s	☆
C2-63	Acceleration time of Segment 13	0.0S-3000.0S	10.0s	☆
C2-64	deceleration time of Segment 14	0.0S-3000.0S	10.0s	☆
C2-65	Acceleration time of Segment 14	0.0S-3000.0S	10.0s	☆
C2-66	deceleration time of Segment 15	0.0S-3000.0S	10.0s	☆
C2-67	Acceleration time of Segment 15	0.0S-3000.0S	10.0s	☆
Group C3: Swing Frequency, Fixed Length and Count				
C3-00	Pressure set (MPa)	0.000~60.000Mpa	0.000Mpa	☆
C3-01	full scale maximum pressure (MPa)	0.000~60.000Mpa	1.000Mpa	☆
C3-03	Explosion-proof tube protection pressure (MPa)	0.001~60.000Mpa	1.500Mpa	☆
C3-04	Sleep wakeup pressure (MPa)	0.0~100% (Corresponding to the set pressure percentage)	80%	☆
C3-07	Sleep frequency	0.00~maximum frequency	20.00HZ	☆
C3-08	The lasting time of frequency is less than	0~250s	10s	☆

Code	Parameter Name	Functional description	Default	Property
	sleep pressure			
C3-09	Sleep selection	0: Frequency sleep available(b2-24~b2-27) 1: Pressure sleep available(C3-04~C3-08)	1	☆
Group d0: Motor 1 Parameters				
d0-00	Rated motor power	0.1kW~1000.0 kW	Model dependent	★
d0-01	Rated motor voltage	1V~2000 V	Model dependent	★
d0-02	Rated motor current	0.01A~655.35 A (Frequency inverter power ≤55 kW) 0.1A~6553.5 A (Frequency inverter power ≥75 kW)	Model dependent	★
d0-03	Rated motor frequency	0.01 Hz~ maximum frequency	50.00Hz	★
d0-04	Rated motor rotational speed	1rpm~65535rpm	Model dependent	★
d0-05	Stator resistance (asynchronous motor)	0.001 Ω ~65.535 Ω (Power≤55 kW) 0.0001 Ω ~6.5535 Ω (Power ≥75 kW)	Model dependent	★
d0-06	Rotor resistance (asynchronous motor)	0.001 Ω ~65.535 Ω (Power≤55 kW) 0.0001 Ω ~6.5535 Ω (Power ≥75 kW)	Model dependent	★
d0-07	Leakage inductive reactance (asynchronous motor)	0.01mH~655.35 mH (Power≤55 kW) 0.001mH~65.535 mH (Power ≥75 kW)	Model dependent	★
d0-08	Mutual inductive	0.1mH~6553.5 mH Power≤	Model	★

Code	Parameter Name	Functional description	Default	Property
	reactance (asynchronous motor)	55 kW) 0.01mH~655.35 mH (Power \geq 75 kW)	dependent	
d0-09	No-load current (asynchronous motor)	0.01A ~ d0-02 (Power \leq 55 kW) 0.1A to d0-02 (Power \geq 75 kW)	Model dependent	★
d0-15	Stator resistance (synchronous motor)	0.001 Ω ~65.535 Ω (Power \leq 55 kW) 0.0001 Ω ~ 6.5535 Ω (Power \geq 75 kW)	Model dependent	★
d0-16	Shaft D inductance (synchronous motor)	0.01 mH ~655.35 mH (Power \leq 55 kW) 0.001~65.535 mH (Power \geq 75 kW)	Model dependent	★
d0-17	Shaft Q inductance (synchronous motor)	0.01 mH ~655.35 mH (Power \leq 55 kW) 0.001 mH~65.535 mH (Power \geq 75 kW)	Model dependent	★
d0-18	Back EMF (synchronous motor)	0.1V~6553.5 V	Model dependent	★
d0-21	Encoder pulses per revolution	1~32767	1024	★
d0-22	Encoder type selection	0: ABZ incremental encoder	0	★
d0-23	Encoder input direction	0: Forward 1: Reverse	0	★
d0-29	Encoder fault detection time	0.0s: No action 0.1s~10.0s	0.0s	★
d0-30	Motor auto-tuning selection	0: No auto-tuning 1: Asynchronous motor static auto-tuning	0	★

Code	Parameter Name	Functional description	Default	Property
		2: Asynchronous motor dynamic complete auto-tuning 3: Asynchronous motor static complete auto-tuning		
Group d1: Vector Control Parameters				
d1-00	Speed/Torque control selection	0: Speed control 1: Torque control	0	★
d1-01	Speed loop proportional gain 1(Kp1)	1~100	30	☆
d1-02	Speed loop integral time 1(Ti1)	0.01s~10.00s	0.50s	☆
d1-03	Switchover frequency 1	0.00HZ ~ d1-06	5.00 Hz	☆
d1-04	Speed loop proportional gain 2(KP2)	1~100	20	☆
d1-05	Speed loop integral time 2(Ti2)	0.01s~10.00s	1.00s	☆
d1-06	Switchover frequency 2	d1-03~ maximum output frequency	10.00 Hz	☆
d1-07	Motor running slip gain	50%~200%	100%	☆
d1-09	Vector control over excitation gain	0~200	64	☆
d1-10	Motor running torque upper limit source in speed control mode	0: d1-16 1: AI1 2: AI2 3: AI3 4: Pulse setting (HDI) 5: Communication setting	0	☆
d1-11	Electric torque limit	0.0%~200.0%	150.0%	☆
d1-14	Excitation current loop proportional gain	1~30000	2000	☆

Code	Parameter Name	Functional description	Default	Property
d1-15	Excitation current loop integral gain	0~30000	1300	☆
d1-16	Torque current loop proportional gain	1~30000	2000	☆
d1-17	Torque current loop integral gain	0~30000	1300	☆
d1-18	Speed loop integral property	0: Integral separation disabled 1: Integral separation enabled	0	☆
d1-21	Maximum output voltage coefficient	100%~110%	105%	☆
d1-22	Max. torque coefficient of field weakening area	50%~200%	100%	☆
d1-24	Torque setting source in torque control	0: Digital setting (d1-27) 1: AI1 2: AI2 3: AI3 4: Pulse setting (HDI) 5: Communication setting 6: MIN (AI1, AI2) 7: MAX (AI1, AI2) Full range of values 1~7 corresponds to the digital setting of d1-27.	0	☆
d1-26	Torque digital setting in torque control	-200.0%~200.0%	150.0%	☆
d1-28	Forward maximum frequency in torque control	0.00 Hz ~ maximum frequency(b0-13)	50.00 Hz	☆
d1-29	Reverse maximum frequency in torque	0.00 Hz ~ maximum frequency(b0-13)	50.00 Hz	☆

Code	Parameter Name	Functional description	Default	Property
	control			
d1-30	Acceleration time in torque control	0.00s~650.00s	0.00s	☆
Group d2: V/F Control Parameters				
d2-00	V/F curve setting	0: Linear V/F 1: Multi-point V/F 2: Square V/F 3: 1.2-power V/F 4: 1.4-power V/F 6: 1.6-power V/F 8: 1.8-power V/F 10: V/F complete separation 11: V/F half separation	0	★
d2-01	Torque boost	0.0% (torque auto-boost) 0.1%~30.0%	Model dependent	★
d2-02	Cut-off frequency of torque boost	0.0%~80.0% Actual cut-off frequency= Motor rated frequency*(d2-02)	50.0%	★
d2-03	Multi-point V/F frequency 1 (F1)	0.00 Hz ~ d2-05	0.00 Hz	☆
d2-04	Multi-point V/F voltage 1 (V1)	0.0%~100.0%	0.0%	☆
d2-05	Multi-point V/F frequency 2 (F2)	d2-03 to d2-07	0.00 Hz	☆
d2-06	Multi-point V/F voltage 2 (V2)	0.0%~100.0%	0.0%	☆
d2-07	Multi-point V/F frequency 3 (F3)	d2-05 ~ maximum frequency	0.00 Hz	☆
d2-08	Multi-point V/F voltage 3 (V3)	0.0%~100.0%	0.0%	☆

Code	Parameter Name	Functional description	Default	Property
d2-09	V/F slip compensation coefficient	0.0%~200.0%	0.0%	☆
d2-11	V/F oscillation suppression gain	0~100	40	☆
d2-13	V/F curve setting	0: Digital setting (d2-13) 1: AI1 2: AI2 3: AI3 4: Pulse setting (HDI) 5: Multi-function 6: Simple PLC 7: PID 8: Communication setting (Note: 100.0% corresponds to the rated motor voltage)	0	☆
d2-14	Voltage digital setting for V/F separation	0 V ~ rated motor voltage	0 V	☆
d2-15	Voltage rise time of V/F separation	0.0s~1000.0s Note: It indicates the time for the voltage rising from 0 V ~ rated motor voltage.	0.0s	☆
Group d6: Control Optimization Parameters 1				
d6-00	Carrier frequency	0.5kHz~16.0 kHz	Model dependent	☆
d6-01	DPWM switchover frequency upper limit	5.00Hz~15.00 Hz	8.00 Hz	★
d6-02	PWM modulation mode	0: Asynchronous modulation 1: Synchronous modulation	0	★
d6-03	Carrier frequency adjustment with temperature	0: No 1: Yes	1	☆

Code	Parameter Name	Functional description	Default	Property
d6-04	Dead zone compensation mode selection	0: No compensation 1: Compensation mode 1 2: Compensation mode 2	1	☆
d6-05	Random PWM depth	0: Random PWM invalid 1~10: Random PWM carrier frequency depth	0	☆
d6-06	Current detected compensation	0~100	0	★
d6-07	SVC mode selection	1: SVC mode 1 2: SVC mode 2	2	☆
Group U0: Standard Monitoring Parameters				
U0-00	Running frequency	0.00~300.00 Hz (b0-11 = 2)	-	●
U0-01	Setting frequency	0.00~3000.0 Hz (b0-11 = 1)	-	●
U0-02	DC Bus voltage	0.0~3000.0 V	-	●
U0-03	Output voltage	0V~1140 V	-	●
U0-04	Output current	0.00A~655.35 A (Frequency inverter power ≤ 55 kW) 0.0A~6553.5 A (Frequency inverter power > 55 kW)	-	●
U0-05	Output power	0~32767	-	●
U0-06	Output torque	-200.0%~200.0%	-	●
U0-07	DI state	0~32767	-	●
U0-08	DO state	0~1023	-	●
U0-09	AI1 voltage	-	-	●
U0-10	AI2 voltage	-	-	●
U0-11	AI3 voltage	-	-	●
U0-14	Load speed display	0~65535	-	●
U0-15	PID setting	0~65535	-	●
U0-16	PID feedback	0~65535	-	●
U0-17	PLC stage	-	-	●

Code	Parameter Name	Functional description	Default	Property
U0-18	Input pulse frequency	0.00kHz ~100.00 kHz	-	●
U0-19	Feedback speed, unit:0.01Hz	-3000.0Hz~3000.0 Hz -300.00Hz~300.00 Hz	-	●
U0-20	Remaining running time	0.0min~6500.0 min	-	●
U0-21	AI1 voltage before correction	0.00V~10.57 V	-	●
U0-22	AI2 voltage before correction	0.00V~10.57 V	-	●
U0-23	AI3 voltage before correction	-10.57V~10.57 V	-	●
U0-24	Linear speed	0.0min~65535m/min	-	●
U0-26	Present running time	-	-	●
U0-28	Communication setting value	-100.00%~100.00%	-	●
U0-29	Encoder feedback speed	-3000.0Hz~3000.0 Hz -300.00Hz~300.00 Hz	-	●
U0-30	Main frequency X	0.00Hz~300.00 Hz 0.0Hz~3000.0 Hz	-	●
U0-31	Auxiliary frequency Y	0.00Hz~300.00 Hz 0.0Hz~3000.0 Hz	-	●
U0-32	Viewing any register address value	0°C~200°C	-	●
U0-34	Motor temperature	0°C~200°C	-	●
U0-35	Target torque	-200.0%~200.0%	-	●
U0-37	Power factor angle	-	-	●
U0-38	ABZ position	0~65535	-	●
U0-39	Target voltage of V/F separation	0 V ~ rated motor voltage	-	●
U0-40	Output voltage of V/F separation	0 V ~ rated motor voltage	-	●
U0-41	DI input state visual	-	-	●

Code	Parameter Name	Functional description	Default	Property
	display			
U0-42	DO output state visual display	-	-	●
U0-43	DI function state visual display 1	-	-	●
U0-44	DO function state visual display 2	-	-	●
U0-45	Fault information	-	-	●
U0-58	Phase Z signal counting	-	-	●
U0-59	Present setting frequency (%)	-100.00%~100.00%	-	●
U0-60	Present running frequency (%)	-100.00%~100.00%	-	●
U0-61	Frequency inverter running state	0~65535	-	●
U0-62	Current fault code	0~99	-	●
U0-63	Sent value of point-point communication	-100.00%~100.00%	-	●
U0-64	Number of slaves	0~63	-	●
U0-65	Torque upper limit	-200.00%~ 200.00%	-	●
Group A0: System Parameters				
A0-00	User password	0~65535	0	☆
A0-01	Product number	Frequency inverter product number	Model dependent	●
A0-02	Software version	Software version of control board	Model dependent	●
A0-06	Function parameters selection	00: Not display 01: Display	01	☆
A0-07	Parameter modification property	0: Modifiable 1: Not modifiable	0	☆
A0-09	Restore default settings	0: No operation	0	★

Code	Parameter Name	Functional description	Default	Property
		1: Restore default settings except motor parameters and accumulation record. 2: Restore default settings include motor parameters 4: Clear records		
A0-11	Parameter copy	1:The machine parameter upload to the keyboard. 2:Keyboard function download to the machine.	--	★
Group A2: Control Optimization Parameters 2				
A2-00	Current limit level	50%~200%	150%	☆
A2-01	Current limit selection	0~1	1	☆
A2-02	Current limit gain	0~100	20	☆
A2-03	Compensation factor of speed multiplying current limit	50%~200%	50%	☆
A2-04	Voltage limit	200.0V~2000.0V	760V	☆
A2-05	Voltage limit selection	0~1	1	☆
A2-06	Frequency gain for voltage limit	0~100	30	☆
A2-07	Voltage gain for voltage limit	0~100	30	☆
A2-08	Frequency rise threshold during voltage limit	0~50Hz	5Hz	☆
A2-09	Slip compensation time constant	0.1s~10.0s	0.5s	☆
A2-10	Automatic frequency boost enable	0~1	0	☆
A2-11	Min motoring torque current	10%~100%	50%	☆

Code	Parameter Name	Functional description	Default	Property
A2-12	Max regenerative torque current	10%~100%	20%	☆
A2-13	Auto-rise frequency KP	0~100	50	☆
A2-14	Auto-rise frequency KI	0~100	50	☆
A2-15	Torque compensation gain	80~150	100	☆
A2-16	Rotational speed tracking closed loop current KP	0~1000	500	☆
A2-17	Rotational speed tracking closed loop current KI	0~1000	800	☆
A2-18	Rotational speed tracking closed loop current limit	30%~200%	Model dependent	☆
A2-19	Rotational speed tracking closed loop current lower limit	10%~100%	30%	☆
A2-20	Time of rotational speed tracking voltage rise	0.5s~3.0s	1.1s	☆
A2-21	Demagnetization time	0.00s~5.00s	1.0s	☆
A2-22	Braking applied voltage	650V~800V	690V	☆

4.7 Fault Alarm and Countermeasures

EM10 inverter has 35 types of warning information and protection function. In case of abnormal fault, the protection function will be invoked, the inverter will stop output, and the faulty relay contact of the inverter will start, and the fault code will be displayed on the display panel of the inverter. Before consulting the service department, the user can perform self-check according to the prompts of this chapter, analyze the fault cause and find out solution. If the fault is caused by the reasons as described in the dotted frame, please consult the agents of inverter or our company directly. Among the 35 types of warning information, Err22 is hardware over current or over voltage signal. In most cases, the hardware

over voltage fault will cause Err22 alarm.

Fault Type	Display	Possible Causes	Solutions
Inverter unit protection	Err01	1: The output circuit is grounded or short circuited. 2: The connecting cable of the motor is too long. 3: The IGBT overheat. 4: The internal connections become loose. 5: The main control board is faulty. 6: The drive board is faulty. 7: The inverter IGBT is faulty.	1: Eliminate external faults. 2: Install a reactor or an output filter. 3: Check the air filter and the cooling fan. 4: Connect all cables properly. 5: Ask for technical support 6: Ask for technical support 7: Ask for technical support
Over current during acceleration	Err02	1: The output circuit is grounded or short circuited. 2: Motor auto-tuning is not performed. 3: The acceleration time is too short. 4: Manual torque boost or V/F curve is not appropriate. 5: The voltage is too low. 6: The startup operation is performed on the rotating motor. 7: A sudden load is added during acceleration.	1: Eliminate external faults. 2: Perform the motor auto-tuning. 3: Increase the acceleration time. 4: Adjust the manual torque boost or V/F curve. 5: Adjust the voltage to normal range. 6: Select rotational speed tracking restart or start the motor after it stops. 7: Remove the added load.

Fault Type	Display	Possible Causes	Solutions
		8: The frequency inverter model is of too small power class.	8: Select a frequency inverter of higher power class.
Over current during deceleration	Err03	1: The output circuit is grounded or short circuited. 2: Motor auto-tuning is not performed. 3: The deceleration time is too short. 4: The voltage is too low. 5: A sudden load is added during deceleration. 6: The braking unit and braking resistor are not installed.	1: Eliminate external faults. 2: Perform the motor auto-tuning. 3: Increase the deceleration time. 4: Adjust the voltage to normal range. 5: Remove the added load. 6: Install the braking unit and braking resistor.
Over current at constant speed	Err04	1: The output circuit is grounded or short circuited. 2: Motor auto-tuning is not performed. 3: The voltage is too low. 4: A sudden load is added during operation. 5: The frequency inverter model is of too small power class.	1: Eliminate external faults. 2: Perform the motor auto-tuning. 3: Adjust the voltage to normal range. 4: Remove the added load. 5: Select an Frequency inverter of higher power class.
Overvoltage	Err05	1: The input voltage is	1: Adjust the voltage to

Fault Type	Display	Possible Causes	Solutions
during acceleration		too high. 2: An external force drives the motor during acceleration. 3: The acceleration time is too short. 4: The braking unit and braking resistor are not installed.	normal range. 2: Cancel the external force or install a braking resistor. 3: Increase the acceleration time. 4: Install the braking unit and braking resistor.
Overvoltage during deceleration	Err06	1: The input voltage is too high. 2: An external force drives the motor during deceleration. 3: The deceleration time is too short. 4: The braking unit and braking resistor are not installed.	1: Adjust the voltage to normal range. 2: Cancel the external force or install the braking resistor. 3: Increase the deceleration time. 4: Install the braking unit and braking resistor.
Overvoltage at constant speed	Err07	1: The input voltage is too high. 2: An external force drives the motor during deceleration.	1: Adjust the voltage to normal range. 2: Cancel the external force or install the braking resistor.
Control power supply fault	Err08	The input voltage is not within the allowable range.	Adjust the input voltage to the allowable range.
Low voltage	Err09	1: Instantaneous power failure occurs on the input power supply. 2: The frequency inverter's input voltage is	1: Reset the fault. 2: Adjust the voltage to normal range.

Fault Type	Display	Possible Causes	Solutions
		not within the allowable range. 3: The DC bus voltage is abnormal. 4: The rectifier bridge and buffer resistor are faulty. 5: The drive board is faulty. 6: The main control board is faulty.	3: Ask for technical support 4: Ask for technical support 5: Ask for technical support 6: Ask for technical support
Frequency inverter overload	Err10	1: The load is too heavy or locked- rotor occurs on the motor. 2: The frequency inverter model is of too small power class.	1: Reduce the load and check the motor and mechanical condition. 2: Select a frequency inverter of higher power class.
Motor overload	Err11	1: bb-02 is set improperly. 2: The load is too heavy or locked- rotor occurs on the motor. 3: The frequency inverter model is of too small power class.	1: Set bb-02 correctly. 2: Reduce the load and check the motor and the mechanical condition. 3: Select a frequency inverter of higher power class.
Power input phase loss	Err12	1: The three-phase power input is abnormal. 2: The drive board is faulty. 3: The lightningproof board is faulty. 4: The main control	1: Eliminate external faults. 2: Ask for technical support. 3: Ask for technical support. 4: Ask for technical

Fault Type	Display	Possible Causes	Solutions
Power output phase loss	Err13	board is faulty. 1: The cable connecting the frequency inverter and the motor is faulty. 2: The frequency inverter's three-phase outputs are unbalanced when the motor is running. 3: The drive board is faulty. 4: The IGBT module is faulty.	support. 1: Eliminate external faults. 2: Check whether the motor three phase winding is normal. 3: Ask for technical support. 4: Ask for technical support.
IGBT Module overheat	Err14	1: The ambient temperature is too high. 2: The air filter is blocked. 3: The fan is damaged. 4: The thermally sensitive resistor of the IGBT module is damaged. 5: The inverter IGBT module is damaged.	1: Lower the ambient temperature. 2: Clean the air filter. 3: Replace the damaged fan. 4: Replace the damaged thermally sensitive resistor. 5: Replace the inverter module.
External equipment fault	Err15	1: External fault signal is input via DI. 2: External fault signal is input via virtual I/O.	1: Reset the operation. 2: Reset the operation.
Communication fault	Err16	1: The host computer is in abnormal state. 2: The communication cable is faulty. 3: The communication	1: Check the cabling of host computer. 2: Check the communication cabling. 3: Set the communication

Fault Type	Display	Possible Causes	Solutions
		extension card is set improperly. 4: The communication parameters in group bA are set improperly.	extension card correctly. 4: Set the communication parameters properly.
Contactor fault	Err17	1: The drive board and power supply are faulty. 2: The contactor is faulty.	1: Replace the faulty drive board or power supply board. 2: Replace the faulty contactor.
Current detection fault	Err18	1: The HALL device is faulty. 2: The drive board is faulty.	1: Replace the faulty HALL device. 2: Replace the faulty drive board.
Motor auto-tuning fault	Err19	1: The motor parameters are not set according to the nameplate. 2: The motor auto-tuning times out.	1: Set the motor parameters according to the nameplate properly. 2: Check the cable connecting the Frequency inverter and the motor.
Encoder fault	Err20	1: The encoder type is incorrect. 2: The cable connection of the encoder is incorrect. 3: The encoder is damaged. 4: The PG card is faulty.	1: Set the encoder type correctly based on the actual situation. 2: Eliminate external faults. 3: Replace the damaged encoder. 4: Replace the faulty PG card.
EEPROM read-write fault	Err21	The EEPROM chip is damaged.	Replace the main control board.

Fault Type	Display	Possible Causes	Solutions
Frequency inverter hardware fault	Err22	1: Overvoltage exists. 2: Over current exists.	1: Handle based on over voltage. 2: Handle based on over current.
Short circuit to ground	Err23	The motor is short circuited to the ground.	Replace the cable or motor.
Accumulative running time reached	Err26	The accumulative running time reaches the setting value.	Clear the record through parameter A0-09
User-defined fault 1	Err27	1: The signal of user-defined fault 1 is input via DI. 2: The signal of user-defined fault 1 is input via virtual I/O.	1: Reset the operation. 2: Reset the operation.
User-defined fault 2	Err28	1: The signal of user-defined fault 2 is input via DI. 2: The signal of user-defined fault 2 is input via virtual I/O.	1: Reset the operation. 2: Reset the operation.
Accumulative power-on time reached	Err29	The accumulative power-on time reaches the setting value.	Clear the record through parameter A0-09
Off load	Err30	The frequency inverter running current is lower than the setting value.	Check that the load is disconnected or the parameter setting is correct.
PID feedback lost during running	Err31	The PID feedback is lower than the setting of C0-26.	Check the PID feedback signal or set C0-26 to a proper value.

Fault Type	Display	Possible Causes	Solutions
By wave current limiting fault	Err40	1: The load is too heavy or locked- rotor occurs on the motor. 2: The frequency inverter model is of too small power class.	1: Reduce the load and check the motor and mechanical condition. 2: Select a frequency inverter of higher power class.
Motor switchover fault during running	Err41	Change the selection of the motor via terminal during running of the frequency inverter.	Perform motor switchover after the frequency inverter stops.
Too large speed deviation	Err42	1: The encoder parameters are set incorrectly. 2: The motor auto-tuning is not performed. 3: The detection parameters of too large speed deviation are set incorrectly.	1: Set the encoder parameters properly. 2: Perform the motor auto-tuning. 3: Set the detection parameters correctly based on the actual situation.
Motor over-speed	Err43	1: The encoder parameters are set incorrectly. 2: The motor auto-tuning is not performed. 3: The over-speed detection parameters are set incorrectly.	1: Set the encoder parameters properly. 2: Perform the motor auto-tuning. 3: Set the over-speed detection parameters correctly based on the actual situation.
Motor overheat	Err45	1: The cabling of the temperature sensor	1: Check the temperature sensor cabling and

Fault Type	Display	Possible Causes	Solutions
		becomes loose. 2: The motor temperature is too high.	eliminate the cabling fault. 2: Lower the carrier frequency or adopt other heat radiation measures.
Initial position fault	Err51	1: The motor parameters are not too deviation based on the actual situation.	1: Check that the motor parameters are set correctly and whether the setting of rated current is too small.

Appendix I Modbus communication protocol

EM10series of inverter provides RS485 communication interface, and adopts MODBUS communication protocol. User can carry out centralized monitoring through PC/PLC to get operating requirements. And user can set the running command, modify or read the function codes, the working state or fault information of frequency inverter by Modbus communication protocol.

1. About Protocol

This serial communication protocol defines the transmission information and use format in the series communication and it includes master-polling (or broadcasting) format, master coding method and the content includes function code of action, transferring data and error checking. The response of slave is the same structure, and it includes action confirmation, returning the data and error checking etc. If slave takes place the error while it is receiving the information or cannot finish the action demanded by master, it will send one fault signal to master as a response.

2. Application Methods

The frequency inverter will be connected into a “Single-master Multi-slave” PC/PLC control net with RS485 bus as the communication slave.

3. Bus structure

1) Hardware interface.

The “485+” and “485-” terminals on frequency inverter are the communication interfaces of Modbus

2) Topological mode

It is a “Single-master Multi-slave” system. In this network, every communication machine has a unique slave address. One of them is as “master” (usually PC host

machine, PLC and HMI, etc.), actively sends out the communication, to read or write the parameters of slave. Other machines will be used as slave and response to the inquiry/command from master. At one time only one machine can send the data and other machines are in the receiving status. The setup range of slave address is 0 to 247. Zero refers to broadcast communication address. The address of slave must be exclusive in the network.

3) Transmission mode

There provide asynchronous series and half-duplex transmission mode. In the series asynchronous communication, the data is sent out frame by frame in the form of message. According to the Modbus-RTU protocol, when the free time of no transmission in communication data lines is more than the transmission time of 3.5byte, it indicates that a new start of communication frame.

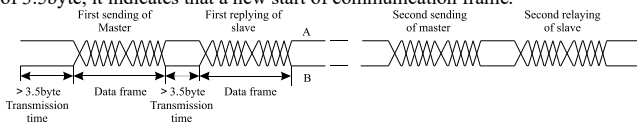

EM10 series inverter has built-in the Modbus-RTU communication protocol, and is applicable to response the slave “Inquiry/command” or doing the action according to the master’s “Inquiry / Command” and response to the data.

Here, master is personnel computer (PC), industrial machine or programmable logical controller (PLC), and the slave is inverter. Master not only visits some slave, but also sends the broadcast information to all the slaves. For the single master “Inquiry/Command”, all of slaves will return a signal that is a response; for the broadcast information provided by master, slave needs not feedback a response to master machine.

Communication data structure

Modbus protocol communication data format of EM10 series inverter is shown as following. The inverter only support the reading and writing of Word type parameters, the corresponding reading operation command is “0x03”, the writing operation command is “0x06”. The writing and reading operation of byte or bit is not supported.

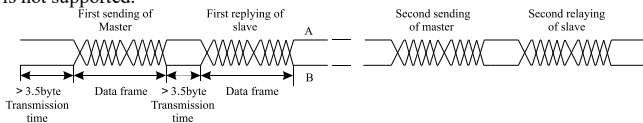

In theory, the host computer can continuously read several function codes once (that is, the maximum value of “n” is 12), but note that not to jump across the last function code in this function group to avoid the wrong reply.

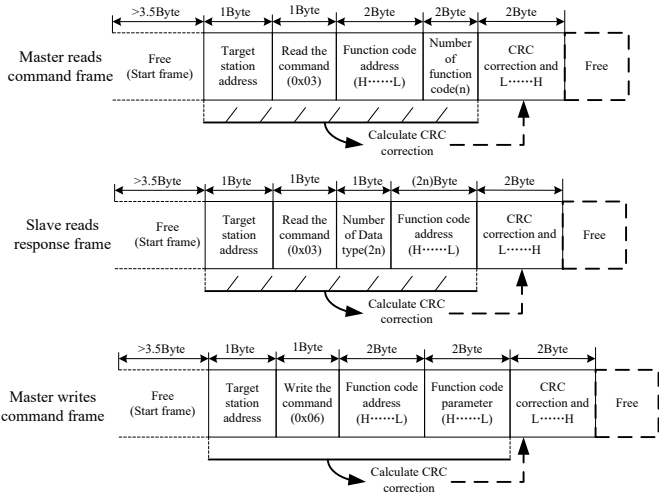

If the wrong communication frame was detected by the slave or other reasons caused the failure of reading and writing, the wrong frame will be replied.

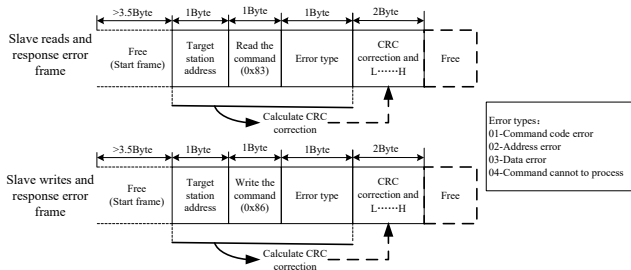

RTU frame format

Frame start (START)	More than the 3.5- character time
Slave address(ADR)	Communication address:1 to 247(0: broadcast address)
Command code(CMD)	03: Read slave parameters 06: Write slave parameters
Function code address(H)	It indicates the external parameter address of frequency inverter in hexadecimal format; There are functional code or non-functional code (such as running state parameter/ running command
Function code address(L)	parameters) type parameters, for details see the address definition. During the transmission, high bit is put in the front, and low bit is at the back.

Number of function code(H)	It indicates the number of function code ready by the frame. If it is "1", then it indicates that it reads one function code. During the transmission, high bit is put in the front, and low bit is at the back.
Number of function code(L)	
Data(H)	It indicates the replying data or the data waiting to write-in. During the transmission, high bit is put in the front, and low bit is at the back.
Data(L)	
END	3.5- character time

Command codes and communication data

Command Code 03H (0000 0011), read N words (can read a maximum of consecutive 12 words).

For example: for an inverter with the slave address of 01H, the start address of memory is 1001H, read 5 words consecutively (Running frequency, DC bus voltage, output voltage, output current, output power), the structure of the frame is as follows:

RTU mode: Command Message of the Master

START	T1-T2-T3-T4
ADDR	01H
CMD	03H
Higher bits of start address	00H
Lower bits of start address	04H
Higher bits of data number	00H
Lower bits of data number	02H

CRC CHK lower bit	85H
CRC CHK higher bit	CAH
END	T1-T2-T3-T4

RTU mode: Response Message of the Slave

START	T1-T2-T3-T4
ADDR	01H
CMD	03H
Higher bits of data number	00H
Lower bits of data number	0AH
Higher bits of running frequency	xxH
Lower bits of running frequency	xxH
Higher bits of DC bus voltage	xxH
Lower bits of DC bus voltage	xxH
Higher bits of output voltage	xxH
Lower bits of output voltage	xxH
Higher bits of output current	xxH
Lower bits of output current	xxH
Higher bits of output power	xxH
Lower bits of output power	xxH
CRC CHK lower bit	xxH
CRC CHK higher bit	xxH
END	T1-T2-T3-T4

Command code 06H (0000 0110), write one word.

For example, write 10000(2710H)(Setting frequency b0-12) into

the address 1000H of the inverter with the slave address of 01H, the structure of the frame is as follows:

RTU mode: Command Message of the Master

START	T1-T2-T3-T4
ADDR	01H
CMD	06H
High bits of data address	10H
Low bits of data address	01H
High bits of data content	27H
Low bits of data content	10H
CRC CHK lower bit	97H
CRC CHK higher bit	36H
END	T1-T2-T3-T4

RTU mode: Response Message of the Slave

START	T1-T2-T3-T4
ADDR	01H
CMD	06H
High bits of data address	10H
Low bits of data address	01H
High bits of data content	27H
Low bits of data content	10H
CRC CHK lower bit	97H
CRC CHK higher bit	36H
END	T1-T2-T3-T4

CRC Checking

In RTU mode, messages include an error-checking field that is based on a CRC method. The CRC field checks the contents of the entire message. The CRC field is two bytes, containing a 16-bit binary value. The CRC value is calculated by the transmitting device, which appends the CRC to the message. The receiving device recalculates a CRC during receipt of the message, and compares the calculated value to the actual value it received in the CRC field.

If the two values are not equal, that means transmission is error

The CRC is started by 0xFFFF. Then a process begins of applying successive eight-bit bytes of the message to the current contents of the register. Only the eight bits of data in each character are used for generating the CRC. Start and stop bits, and the parity bit, do not apply to the CRC. During generation of the CRC, each eight-bit character is exclusive ORed with the register contents. Then the result is shifted in the direction of the least significant bit (LSB), with a zero filled into the most significant bit (MSB) position. The LSB is extracted and examined. If the LSB was a 1, the register is then exclusive ORed with a preset, fixed value. If the LSB was a 0, no exclusive OR takes place. This process is repeated until eight shifts have been performed. After the last (eighth) shift, the next eight-bit byte is exclusive ORed with the register's current value, and the process repeats for eight more shifts as described above. The final contents of the register, after all the bytes of the message have been applied, is the CRC value. When the CRC is appended to the message, the low-order byte is appended first, followed by the high-order byte.

```
unsigned int crc_chk_value(unsigned char *data_value,unsigned char length
    {
        unsigned int crc_value=0xFFFF;
        int i;
```



```
while(length--)  
{  
    crc_value^=*data_value++;  
    for(i=0;i<8;i++)  
    {  
        if(crc_value&0x0001)  
        {  
            crc_value=(crc_value>>1)^0xa001;  
        }  
        else  
        {  
            crc_value=crc_value>>1;  
        }  
    }  
}  
return(crc_value);  
}
```

Definition of communication parameter address

Read and write function-code parameters (Some functional code is not changed, only for the manufacturer use.)

The group number and mark of function code is the parameter address for indicating the rules.

High level bytes: Group A0~AF(GroupA0-A2/ Groupb0-bC), Groupb0-bF(Group C0-C6/Groupd0-d6), 70-7F(Group U)

Low level bytes: 00 to FF

For example: b0-03, address indicates to 0xA303.

Note: Group U: Only for reading parameter, cannot be changed parameters, some

parameters cannot be changed during operation, some parameters regardless of what kind of state the inverter in, the parameters cannot be changed. Change the function code parameters, pay attention to the scope of the parameters, units, and relative instructions.

Function code group	Communication inquiry address	Inquiry address When Communication modifies RAM
A0~A2	0xA000~0xA2FF	0x4000~0x42FF
b0~bC	0xA300~0xAFFF	0x4300~0x4FFF
C0~C6	0xB000~0xB7FF	0x5000~0x57FF
d0~d6	0xB800~0xBEFF	0x5800~0x5EFF
U0	0x7000~0x70FF	

Besides, due to EEPROM be frequently stored, it will reduce the lifetime of EEPROM. In the communication mode, and some function codes don't have to be stored as long as change the RAM value.

Stop/start parameter

Parameter address	Parameter description	Parameter address	Parameter description
1000	Communication set value (-10000 ~ 10000)(Decimal)	1010	PID setting
1001	Running frequency	1011	PID feedback
1002	DC Bus voltage	1012	PLC process
1003	Output voltage	1013	Pulse input frequency, unit: 0.01KHz
1004	Output current	1014	Feedback speed, unit:0.1Hz
1005	Output power	1015	Remaining running time
1006	Output torque	1016	Voltage before All correction

1007	Running speed	1017	Voltage before AI2correction
1008	DI input terminal	1018	Voltage before AI3correction
1009	DO output terminal	1019	Linear speed
100A	AI1 voltage	101A	Present power-on time
100B	AI2 voltage	101B	Present running time
100C	AI3 voltage	101C	Pulse input frequency, unit:1Hz
100D	Counting value input	101D	Communication setting value
100E	Length value input	101E	Actual feedback speed
100F	Load speed	101F	Main frequency X display
		1020	Auxiliary frequency Y display

Note: Communication setting value is the percentage of relative value, 10000 corresponds to 100%, -10000 correspond to -100.00%.

Control command input frequency inverter: (write in only)

Command word address	Command function
2000	0001: Forward running
	0002: Reverse running
	0003: Forward jog
	0004: Reverse jog
	0005: Free stop
	0006:Decelarating stop
	0007: Fault reset

Read inverter status: (read only)

Command word address	Command function
3000	0001: Forward running
	0002: Reverse running
	0003: Stop

Parameter locking password collation: (If the feedback is the 8888H, it indicates the password collation passed)

Password address	Contents of input password
1F00	*****

Digital output terminal control: (write in only)

Address Of locking password command	Contents of locking password command
2001	BIT0: DO1 output control BIT1: DO2 output control BIT2: Relay 1 output control BIT3: Relay 2 output control BIT4: FMR output control BIT5: VDO1 BIT6: VDO2 BIT7: VDO3 BIT8: VDO4 BIT9: VDO5

Analog output AO1 control: (write in only)

Command word address	Command function
2002	0~7FFF indicates 0%~100%

Analog output AO2 control: (write in only)

Command word address	Command function
2003	0~7FFF indicates 0%~100%

Pulse output control: (write in only)

Command word address	Command function
2004	0~7FFF indicates 0%~100%

Inverter fault description:

Fault Address	Inverter fault information	
	8000	0000: No fault 0001: Reserved 0002: acceleration over current 0003: deceleration over current 0004: Constant speed over current 0005: acceleration over voltage 0006: deceleration over voltage 0007: Constant speed over voltage 0008: Buffer resistor fault

0009: less voltage fault	001F: PID lost during running
000A: Frequency inverter overload	0028: fast current limit fault
000B: Motor overload	0029: Motor switchover fault during running
000C: Input phase failure	002A: Too large speed deviation
000D: Output phase failure	002B: Motor over-speed
000E: IGBT overheat	002D: Motor overheat
000F: External equipment fault	005A: Encode lines setting fault
0010: Communication fault	005B: Not connect to the encoder
0011: Contactor fault	005C: Initial location fault
0012: Current detection fault	005E: Speed feedback fault
0013: Motor auto-tuning fault	
0014: Encoder/PG fault	

ModBus communication fault address

Address Definition	Fault information	
8001	0000: Not fault 0001: Password error 0002: Command code error 0003: CRC error 0004: Illegal address	0005: Illegal data 0006: Parameter change invalid 0007: System locked 0008: Inverter busy (EEPROM is storing)

Group bA Communication parameters

bA-00	Communication type selection	Default	0
--------------	------------------------------	----------------	---

	Setting Range	0: Modbus protocol
--	----------------------	--------------------

The EM10 now supports Modbus, later will add the communication protocol such as PROFIBUS-DP and CANopen protocol. For details, see the description of “EM10 communication protocol”.

bA-01	Baud ratio setting		Default	5
	Setting Range	0:300BPS	4:4800BPS	
		1:600BPS	5:9600BPS	
		2:1200BPS	6:19200BPS	
	3:2400BPS	7:38400BPS		

This parameter is used to set the data transfer rate from host computer and the frequency inverter. Please note that baud ratio of the host computer and the inverter should be consistent. Otherwise, the communication is impossible. The higher the baud ratio is, the faster the communication is.

bA-02	Modbus Data format		Default	0
	Setting Range	0	No check, data format <8,N,2>	
		1	Even parity check, data format<8,E,1>	
		2	Odd Parity check, data format<8,O,1>	
	3	No check, data format <8,N,1>		

The host computer and frequency inverter setup data format must be consistent, otherwise, communication is impossible.

bA-03	Broadcast address		Default	0
	Setting Range	1~249 (0: Broadcast address)Valid for Modbus		

When the local address is set to 0, that is, broadcast address, it can realize the broadcast function of host computer.

bA-04	Modbus response delay		Default	2 ms
	Setting Range	0~20 ms (Only valid for Modbus)		

Response delay time: it refers to the interval time from the inverter finishes receiving data to sending data to the host machine. If the response time is less than the system processing time, then the response delay time is based on the time delay of the system processing time. If the response delay time is more than the system processing time, after the system processes the data, it should be delayed to wait until the response delay time is reached, then sending data back to host machine.

bA-05	Communication timeout		Default	0.0s
	Setting Range	0.0s:invalid 0.1s~60.0s Valid for Modbus		

When the function is set to 0.0s, the communication interface timeout parameter is invalid.

When the function code is set to time value, if the interval time between the communication and the next communication is beyond the communication timeout, the system will report communication failure error (Err16). At normal circumstances, it will be set as invalid. If in the continuous communication system, set this parameter, you can monitor the communication status.

bA-06	Modbus protocol data transmission format selection		Default	1
	Setting Range	Unit's digit: Modbus protocol.		
		0	Non-standard Modbus protocol	
1	Standard Modbus protocol			

bA-06=1: Select standard Modbus protocol.

bA-06=0: When reading the command, the slave machine return is one byte more

than the standard Modbus protocol's, for details, refer to communication data structure of this protocol.

bA-07	Communication reading current resolution		Default	0
	Setting	0	0.01A	
	Range	1	0.1A	

It is used to confirm the unit of current value when the communication reads the output current.

Appendix II Dimension for special model/EM10

EM10-G13 series dimension:

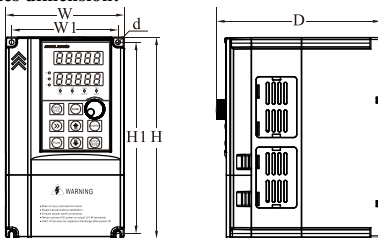

Model	Output Current (A)	Adaptable Motor		Appearance and installing dimension(mm)					
		KW	HP	W	W1	H	H1	D	Φd
1 phase 220V input & 3 phase 380V output									
EM10-G13-d75	2.1	0.75	1	118	106.5	185	175.5	157	Φ4.5
EM10-G13-1d5	3.8	1.5	2						
EM10-G13-2d2	5.1	2.2	3						
EM10-G13-004	9	3.7	5	160	148	247	235	177	Φ5.5
EM10-G13-5d5	13	5.5	7.5						
EM10-G13-7d5	17	7.5	10	220	205	320	305	198	Φ5.5
EM10-G13-011	25	11	15						
EM10-G13-015	32	15	20						
EM10-G13-018	37	18.5	25						

EM10 series dimension:

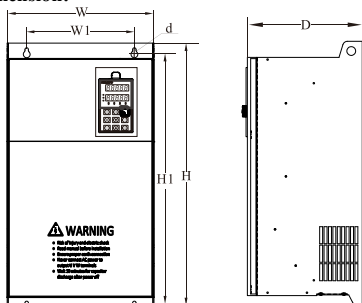

Model	Output Current (A)	Adaptable Motor		Appearance and installing dimension(mm)					
		KW	HP	W	W1	H	H1	D	Φd
EM10-G1-d75	4	0.75	1	101	90	152	141	132	Φ4
EM10-G1-1d5	7	1.5	2						
EM10-G1-2d2	9.6	2.2	3						
EM10-G2-d75	3.8	0.75	1	101	90	152	141	132	Φ4
EM10-G2-1d5	5.1	1.5	2						
EM10-G2-2d2	9	2.2	3						
EM10-G2-004	17	3.7	5	162	148	250	238	191	Φ5.5
EM10-G2-5d5	25	5.5	7.5						
EM10-G2-7d5	32	7.5	10	223	207	323	307	207	Φ5.5
EM10-G2-011	45	11	15						
EM10-G2-015	60	15	20	275	180	438	420	235	Φ8
EM10-G2-018	75	18.5	25						
EM10-G2-022	91	22	30	300	215	490	465	257	Φ10
EM10-G2-030	112	30	40						
EM10-G2-037	150	37	50	335	285	490	465	260	Φ10
EM10-G2-045	176	45	60						

Model	Output Current (A)	Adaptable Motor		Appearance and installing dimension(mm)					
		KW	HP	W	W1	H	H1	D	Φd
EM10-G3-d75/P3-1d5	2.1/3.8	0.75/1.5	1/2	101	90	152	141	132	Φ4
EM10-G3-1d5/P3-2d2	3.8/5.1	1.5/2.2	2/3						
EM10-G3-2d2/P3-004	5.1/9	2.2/3.7	3/5						
EM10-G3-004/P3-5d5	9/13	3.7/5.5	5/7.5	120	108	205	195	166	Φ4.5
EM10-G3-5d5/P3-7d5	13/17	5.5/7.5	7.5/10						
EM10-G3-7d5/P3-011	17/25	7.5/11	10/15	162	148	250	238	191	Φ5.5
EM10-G3-011/P3-015	25/32	11/15	15/20						
EM10-G3-015/P3-018	32/37	15/18.5	20/25	223	207	323	307	207	Φ5.5
EM10-G3-018/P3-022	37/45	18.5/22	25/30						
EM10-G3-022/P3-030	45/60	22/30	30/40						
EM10-G3-030/P3-037	60/75	30/37	40/50	275	180	438	420	235	Φ8
EM10-G3-037/P3-045	75/91	37/45	50/60						
EM10-G3-045/P3-055	91/112	45/55	60/75	300	215	490	465	257	Φ10
EM10-G3-055/P3-075	112/150	55/75	75/100						
EM10-G3-075/P3-090	150/176	75/90	100/125	335	285	490	465	260	Φ10
EM10-G3-090/P3-110	176/210	90/110	125/150						
EM10-G3-110/P3-132	210/253	110/132	150/200	475	320	720	695	335	Φ12
EM10-G3-132/P3-160	253/304	132/160	200/250						
EM10-G3-160	304	160	250						
EM10-G3-200/P3-220	377/426	200/220	280/300	550	360	880	825	360	Φ12
EM10-G3-220/P3-250	426/465	220/250	300/370						
EM10-G3-250/P3-280	465/520	250/280	370/400	670	360	1040	985	415	Φ12
EM10-G3-280/P3-315	520/585	280/315	400/420						
EM10-G3-315/P3-355	585/650	315/355	420/500						
EM10-G3-355	650	355	500	815	600	1300	1235	445	Φ12
EM10-G3-400	725	400	530						
EM10-G3-450	820	450	600						
EM10-G3-500	860	500	660						

Model	Output Current (A)	Adaptable Motor		Appearance and installing dimension(mm)					
		KW	HP	W	W1	H	H1	D	Φd
EM10-G4-d75/P4-1d5	2.1/3.8	0.75/1.5	1/2	101	90	152	141	132	Φ4
EM10-G4-1d5/P4-2d2	3.8/5.1	1.5/2.2	2/3						
EM10-G4-2d2/P4-004	5.1/9	2.2/3.7	3/5						
EM10-G4-004/P4-5d5	9/13	3.7/5.5	5/7.5	120	108	205	195	166	Φ4.5
EM10-G4-5d5/P4-7d5	13/17	5.5/7.5	7.5/10						
EM10-G4-7d5/P4-011	17/25	7.5/11	10/15	162	148	250	238	191	Φ5.5
EM10-G4-011/P4-015	25/32	11/15	15/20						
EM10-G4-015/P4-018	32/37	15/18.5	20/25	223	207	323	307	207	Φ5.5
EM10-G4-018/P4-022	37/45	18.5/22	25/30						
EM10-G4-022/P4-030	45/60	22/30	30/40						
EM10-G4-030/P4-037	60/75	30/37	40/50	275	180	438	420	235	Φ8
EM10-G4-037/P4-045	75/91	37/45	50/60						
EM10-G4-045/P4-055	91/112	45/55	60/75	300	215	490	465	257	Φ10
EM10-G4-055/P4-075	112/150	55/75	75/100						
EM10-G4-075/P4-090	150/176	75/90	100/125	335	285	490	465	260	Φ10
EM10-G4-090/P4-110	176/210	90/110	125/150						
EM10-G4-110/P4-132	210/253	110/132	150/200	475	320	720	695	335	Φ12
EM10-G4-132/P4-160	253/304	132/160	200/250						
EM10-G4-160	304/377	160/200	250/280						
EM10-G4-200/P4-220	377/426	200/220	280/300	550	360	880	825	360	Φ12
EM10-G4-220/P4-250	426/465	220/250	300/370						
EM10-G4-250/P4-280	465/520	250/280	370/400	670	360	1040	985	415	Φ12
EM10-G4-280/P4-315	520/585	280/315	400/420						
EM10-G4-315/P4-355	585/650	315/355	420/500						
EM10-G4-355	650	355	500	815	600	1300	1235	445	Φ12
EM10-G4-400	725	400	530						
EM10-G4-450	820	450	600						
EM10-G4-500	860	500	660						



 Fl. 3, Bldg E, Longda Ind. Park, Bao'an District, Shenzhen, P.R.China, 518108

 (+86)180-6298-1327

 joanna.huang@honyeetech.com

 www.honyeetech.com